

| | |
|---------------------|--------------|
| Uniclass L4181 | EPIC D181 |
| CI/SfB (31.59) X | |

JANUARY 2006

GLASSMASTER™ KABINETTE

GLASS SYSTEMS

Part of the Glassmaster™ series, the Kabinette range of sliding systems for glass* provides a discreet security solution for public areas.

Designed for maximum visibility and protection, the slimline framework presents a stylish, streamlined finish to complement any décor.

The high performance specification of Kabinette will ensure a smooth noise-free operation over many years of use.

Available in a choice of finishes, Kabinette can be supplied in stock sizes or tailored to your specific requirements.

Kabinette is available with a wide variety of fittings including locking mechanisms, offering solutions for both retail and commercial use.



Coburn Kabinette – ideal for use in:

- Reception hatches
- Point of sale displays
- Shopfitting
- Laboratory furniture

*Glass not included

Kabinette

Featuring anodised aluminium rails*, Kabinette is suitable for 6mm glass panels not exceeding 1m² up to a maximum weight of 20Kg.

Max. dimensions: W 1000mm x H 1000mm

*Other finishes available by special order

Packed sets:

HH4 – for 2 panels in 1200mm opening

HH5 – for 2 panels in 1500mm opening

HH6 – for 2 panels in 1800mm opening

Locking is included.

Kabinette Super

Suitable for 6mm-8mm glass, Kabinette Super includes a double top and bottom track and integral locking. A glass rail fitted to the lower edge of the glass panel acts as the holder for the wheel units.

Standard kit for 2 panels in opening up to 1200mm wide x 1000mm high (Other sizes available on request). Locking is included.

Kabinette Deluxe

Kabinette Deluxe is designed for maximum protection against pilferage, as the doors cannot be removed with the silencers in place.

Suitable for 6mm-8mm glass, Kabinette Deluxe features a frame channel, which fits all around the opening. This may be set into surrounding woodwork for added concealment and to maximise the opening. Silencers ensure quiet rattle-free operation.

Standard kit for 2 panels in opening up to 1200mm wide x 1000mm high (Other sizes available on request). Locking is included.

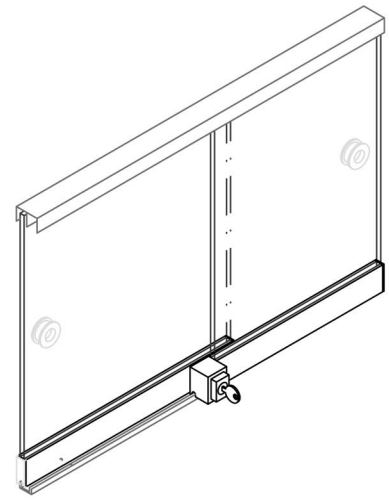

Specifications – Super & Deluxe only

Fitting:

Doors are fitted by first lifting the panel up into the top track, then lowering onto the bottom track. No drilling is required for finger pulls.

Glass Height

Measuring the total inside height of the opening and subtracting either 28mm (Super) or 36mm (Deluxe).

Glass Width

For a two door system, halve overall aperture width and add 25mm (this provides a 50mm overlap)

Wheel Units

Super and Deluxe kits are supplied with 4 steel wheel rollers (2 for each door) to give a maximum weight of 20kgs per door. If a higher weight capacity is required (max 40kgs per door) it is possible to use rollers in tandem (4 per door). These additional rollers can be supplied on request.

An alternative nylon wheel roller is available on request for doors weighing up to 5kgs only.

Choice of silver or gold anodised finishes

Head Office

Unit 6, Wyvern Estate, Beverley Way,
New Malden, Surrey KT3 4PH, UK.

Tel: +44 (0)20 8336 1515 Fax: +44 (0)20 8336 1414

Sales Freefax: 0800 616623 E-mail: sales@hillaldam.co.uk

Scotland

Unit 25, Ballieston Distribution Centre,
Garrawhill, Glasgow G69 6UL, Scotland.

Tel: 0141 771 6165 Fax: 0141 773 1693

Freefax: 0800 318904 E-mail: glasgow@hillaldam.co.uk