



Foldaside 50

Sliding & Folding Door Systems



Product Overview

The Foldaside 50 is a reliable hardware system purpose designed for internal or external folding doors up to 50kg per leaf. The end door within the set is secured using a pivot bearing whilst the other doors are aligned by means of unobtrusive hinges and hangers that bring the panels together.

Features

- For timber, timber framed or composite doors
- Neatly stacking to either one or both sides
- No recessed floor channel necessary with 2 or 3 leaf configurations
- A maximum of six doors can be hinged together
- Suitable for odd or even suites of doors
- Stable and smooth operation



Concealed hinge

Technical Specifications

- Maximum door weight: 50kg
- Maximum door height: 3000mm
- Door Thickness: 25 – 50mm
- Track Dimensions: 47mm (w) x 48mm (h)



Top pivot assembly



4 wheel intermediate hanger



Bottom pivot assembly



Foldaside 50

Maximum door weight 50kg

DH - Door height, maximum door height 3000mm

DWi - Door width, maximum 850mm

DT - Door thickness between 25mm and 50mm
For doors between 25mm and 30mm door plates will be mounted on top and not routed

OW - Opening width

OH - Opening height

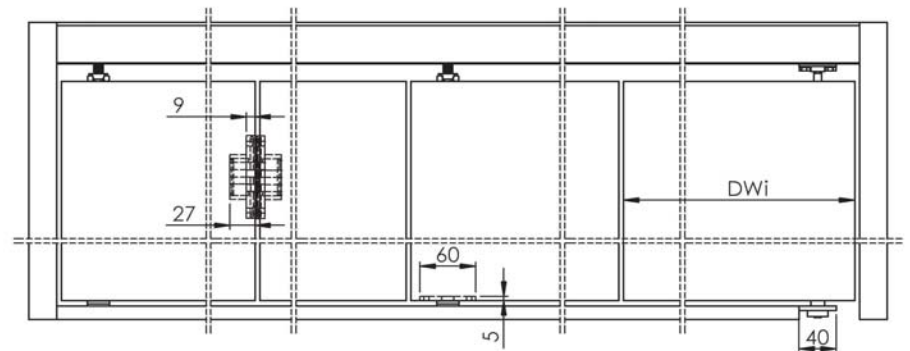
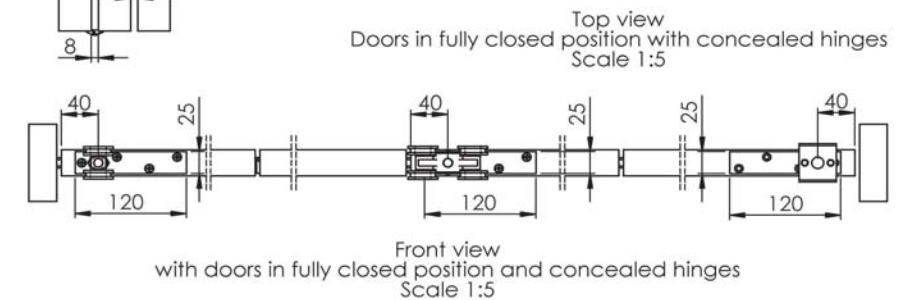
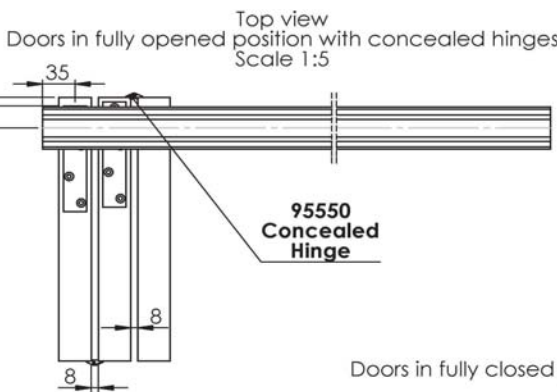
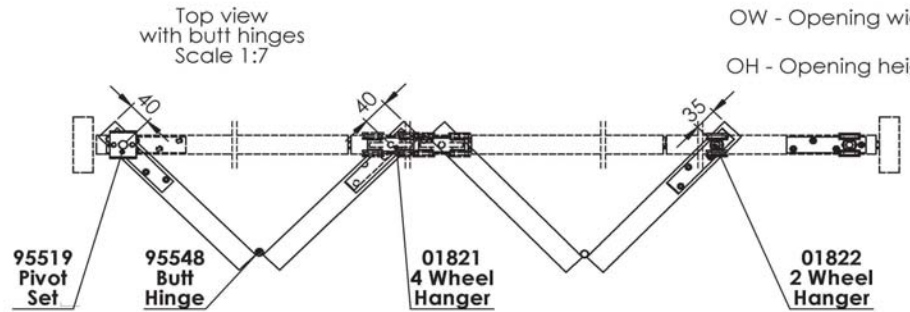
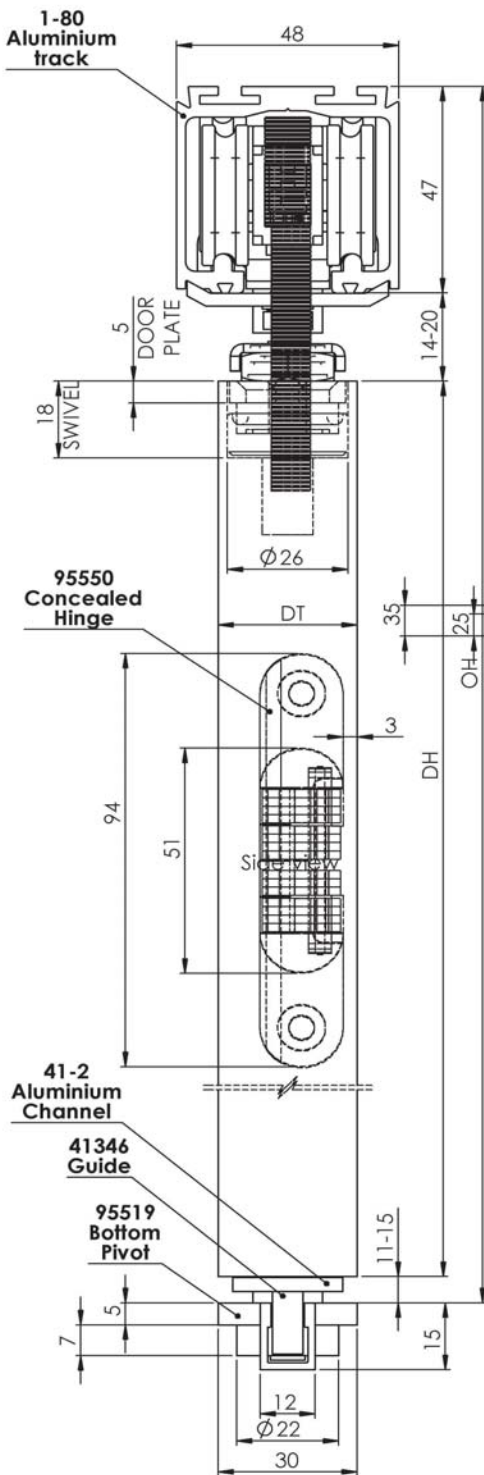

For further information on our products and services:
Tel: +44 (0)20 8545 6680 sales@coburn.co.uk www.coburn.co.uk

Coburn Sliding Systems Limited
Unit 1, Cardinal West, Cardinal Distribution Park,
Godmanchester, Huntingdon, Cambridgeshire, PE29 2XN United Kingdom.

