

FITTING INSTRUCTIONS FOR FLEXIGLAS 50

COMPONENTS



51120/30/40/60 - Anodized Aluminium



51230/40/60 - Satin Stainless Steel

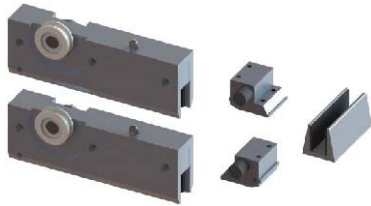

51172 - Flexiglas fitting set, anodized aluminium, 50kg

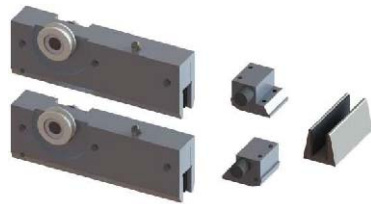

51272 - Flexiglas fitting set, satin stainless steel, 50kg

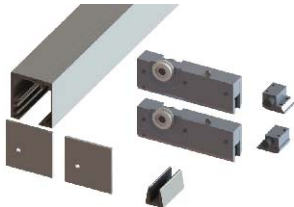

51181 - Flexiglas 50 standard kit, anodized aluminium

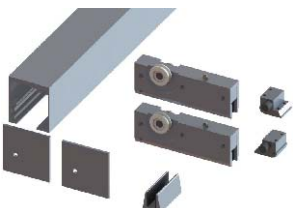

51281 - Flexiglas 50 standard kit, satin stainless steel



51171 - End caps (set of 2), anodized aluminium



51271 - End caps (set of 2), satin stainless steel



51191 - Flexiglas 50, double soft closing kit, 50kg

Required tools

Allen Key



Spanner



Power screw driver



Posi drive screw bit



Drill bit



Technical Specifications

FLEXIGLAS 50

Maximum door weight 50kg

DH - Door height, maximum 2400mm

DWi - Door width

DT - Door thickness, 8mm or 10mm

OW - Opening width

OH - Opening height

Side View
Side Fixing

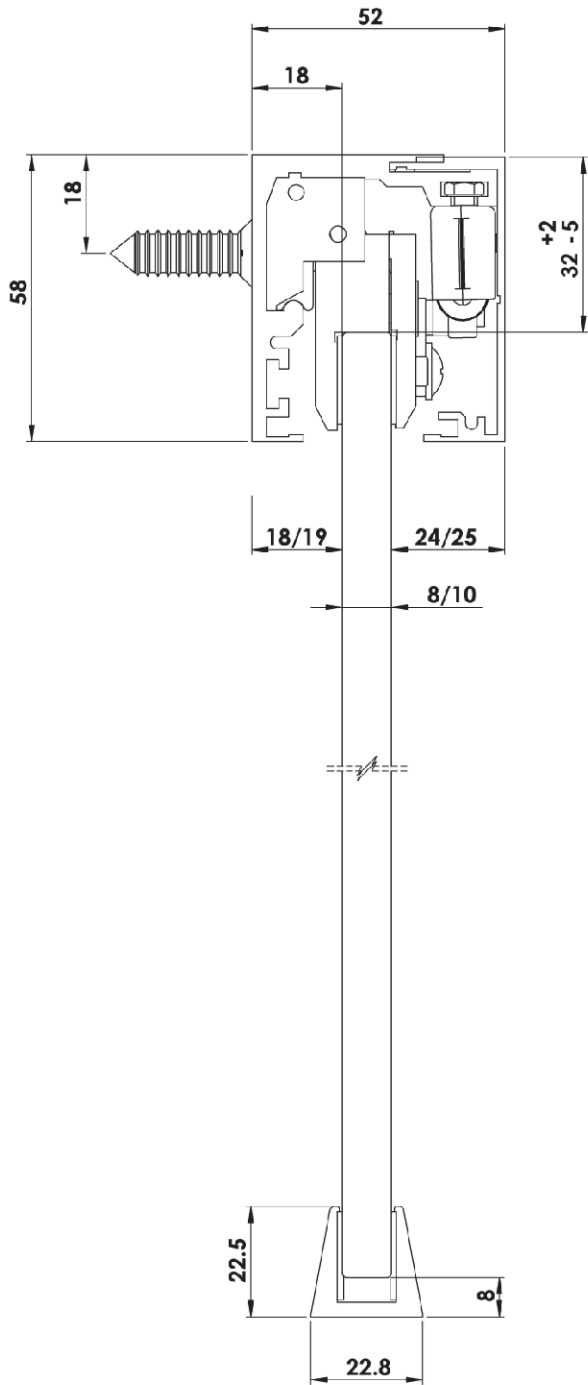

Side View
Soffit Fixing

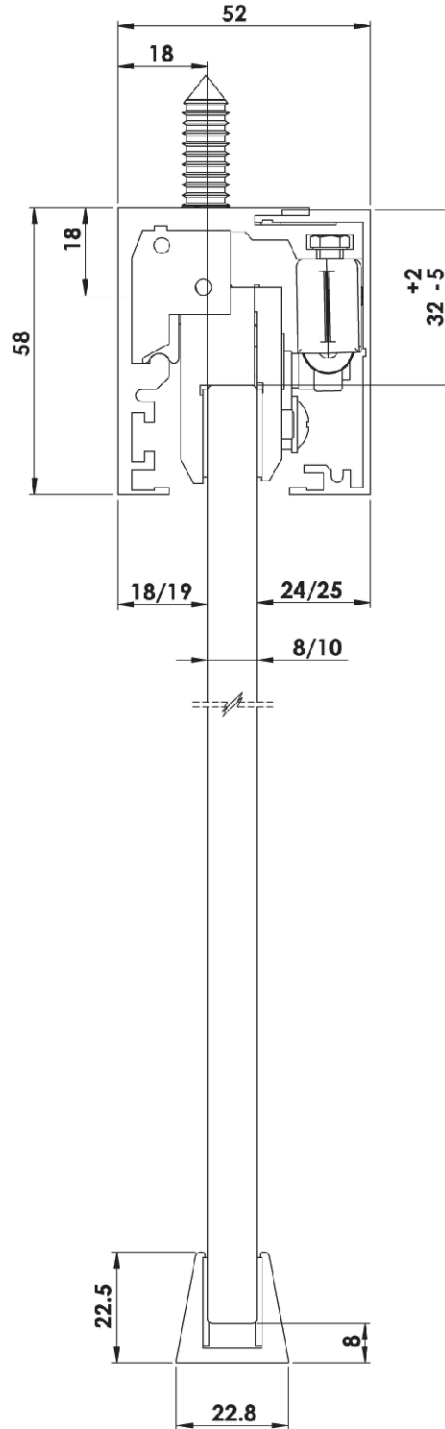

Step 1 Fixing track

Face Fixed: track comes pre-drilled, mark the position of the levelled track on the wall and fix it with screws

Soffit Fixed: track needs to be pre-drilled, mark the ceiling and fix the track with screws

Face Fix



Soffit Fix

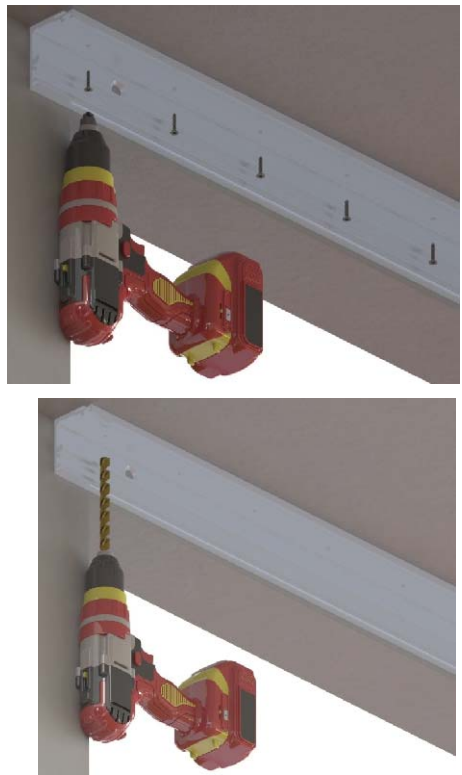

Step 2 Door hardware overview

Soft closer actuator (Soft closer is optional) *(Syncro Kit option is also available)*

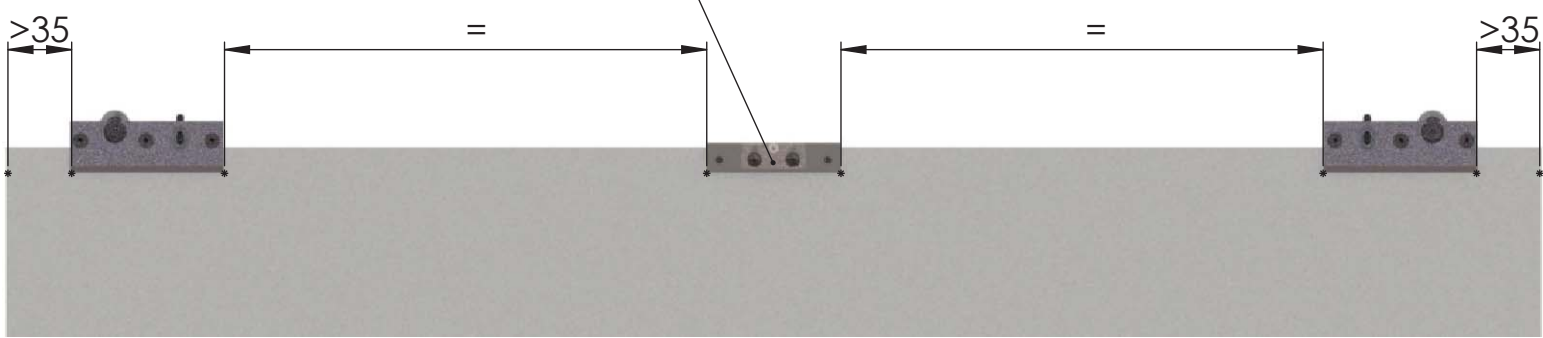

8mm door

10mm door

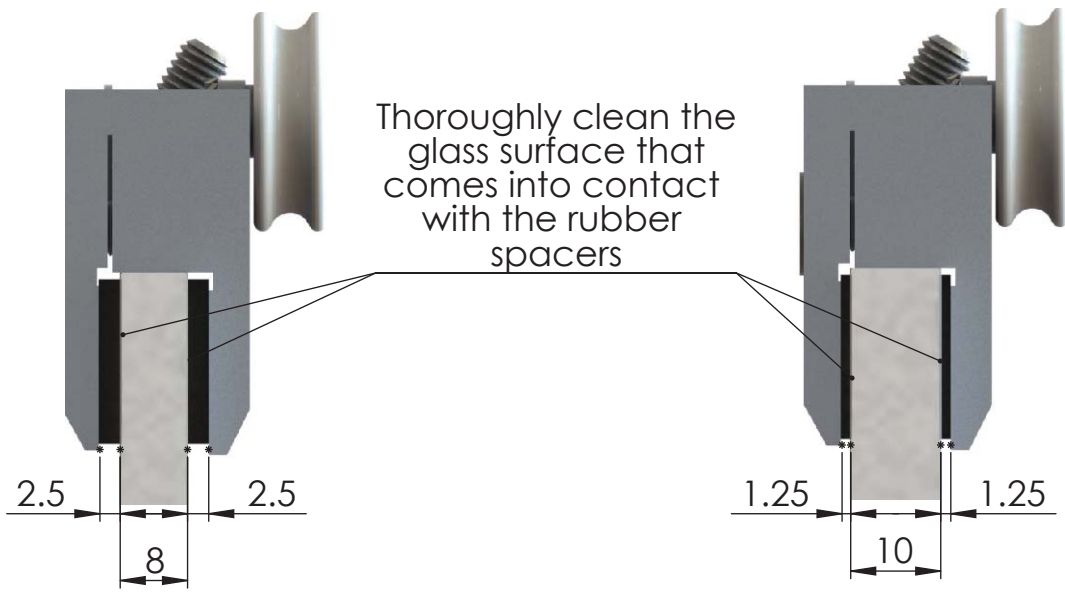

Step 3 Prepare hangers and fix with 10mm door

a. Prepare all required components

b. Insert the rubber spacers on each side between the door and the hanger

DO NOT USE GLUE

c. Tighten the screws with 12Nm force

d. Insert the grub screw

NOTE: If you opted for a soft closer or syncro kit also refer to the appropriate instructions

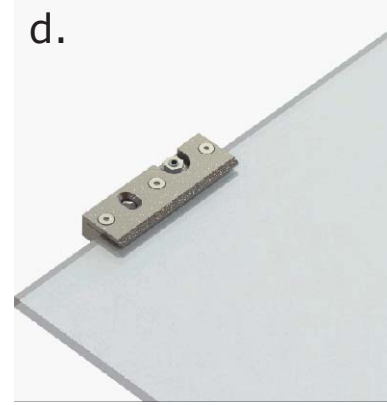
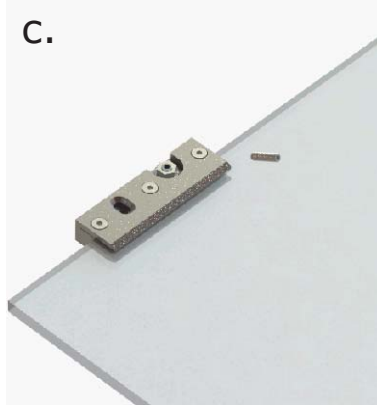
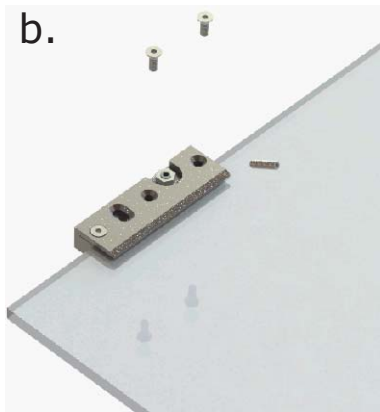

Step 4 Prepare hangers and fix with 8mm door

a. Prepare all required components

b. Insert the rubber spacers on each side between the door and the hanger

DO NOT USE GLUE

c. Tighten the screws with 12Nm force

d. Insert the grub screw

NOTE: If you opted for a soft closer or syncro kit also refer to the appropriate instructions

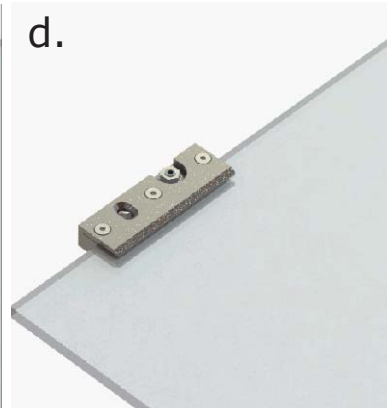
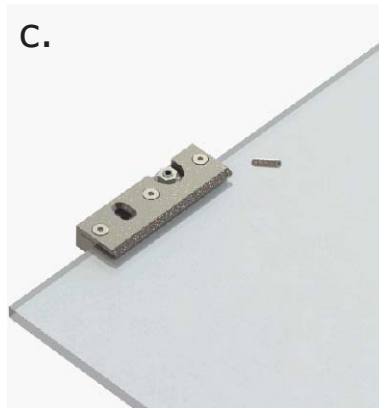
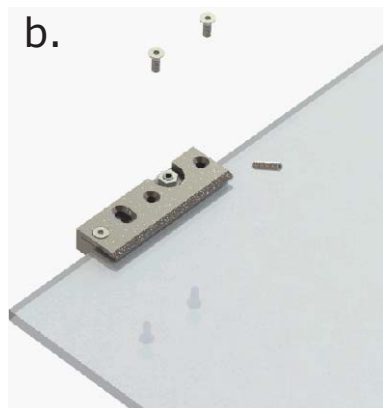

Step 5 Insert door and hangers into track

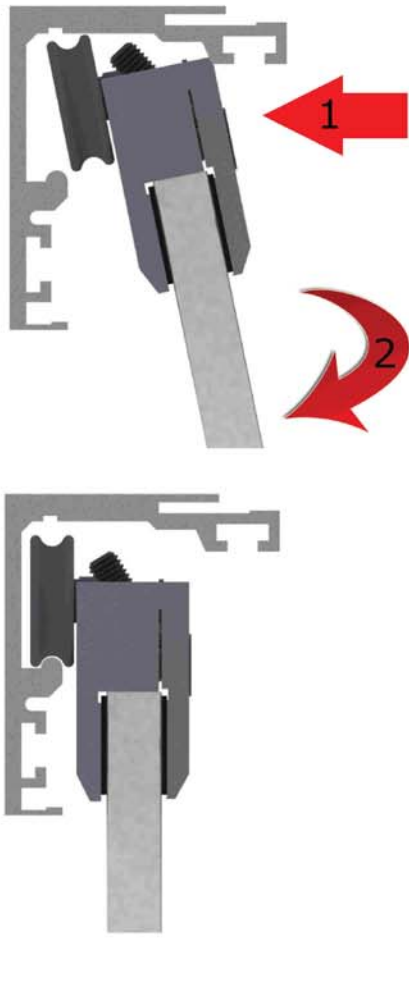

Adjust the height of the door by holding the **RED** nut with a spanner and rotate the **BLUE** grub screw with an allen key

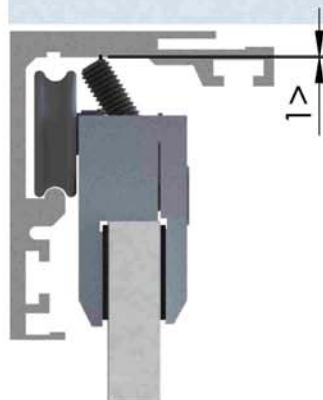
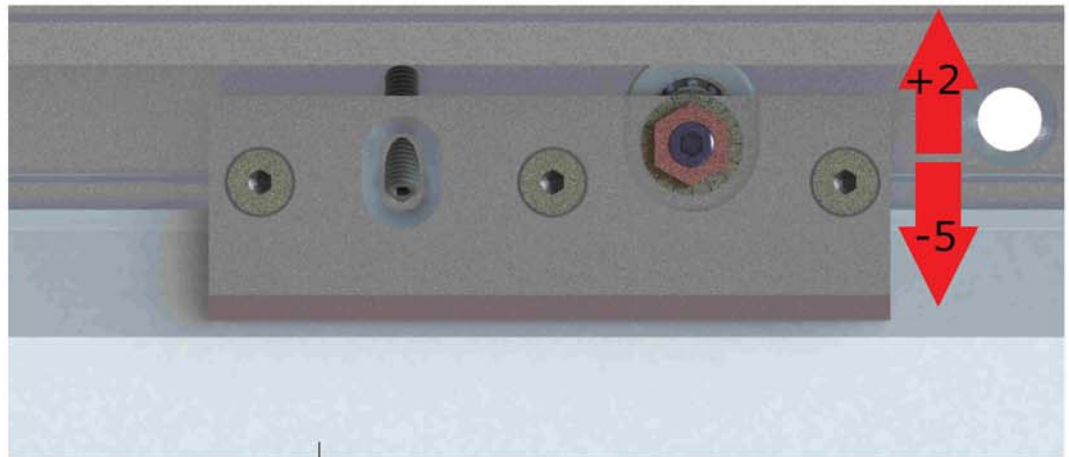

To prevent the hanger from rattling in the track tighten the grub screw and leave a 1mm gap or smaller. Try not to obstruct the movement of the hangers.

Step 6 Install the bottom guide

Ensure the door is level, mark the position of the guide and secure it with screws

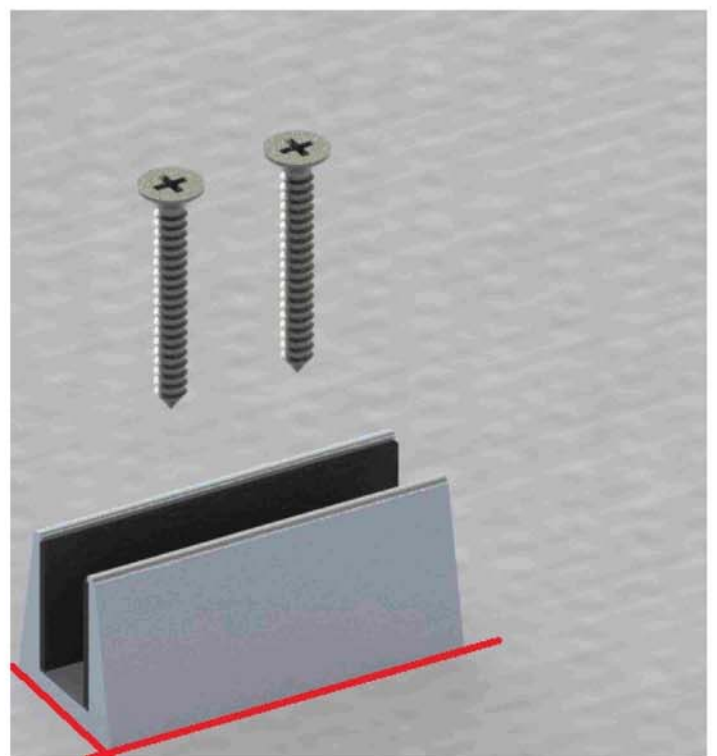
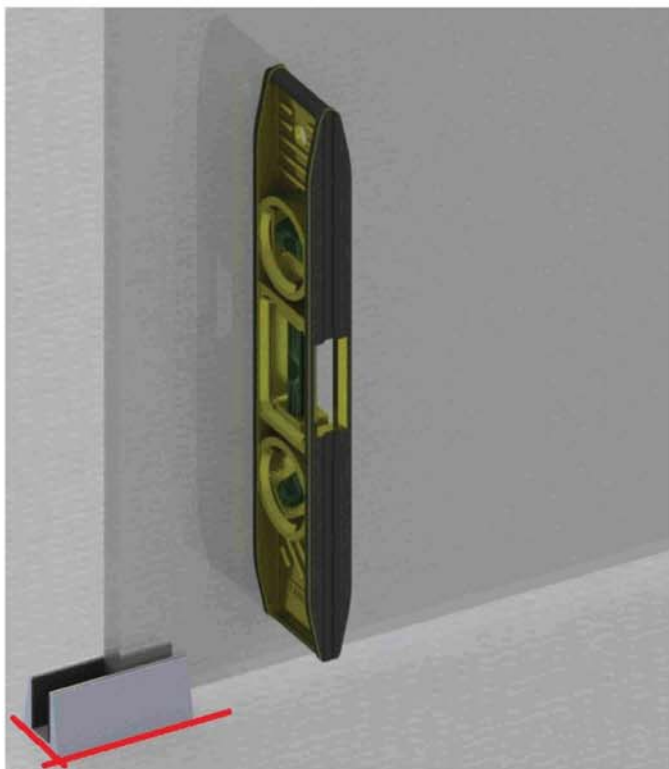

Step 7 Installing stopper and fitting end caps

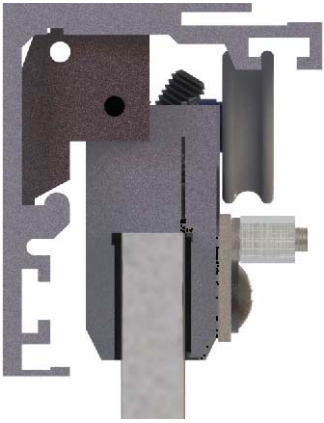

Insert stopper into track and secure it with screws

NOTE: If you opted for a soft closer or syncro kit also refer to the appropriate instructions

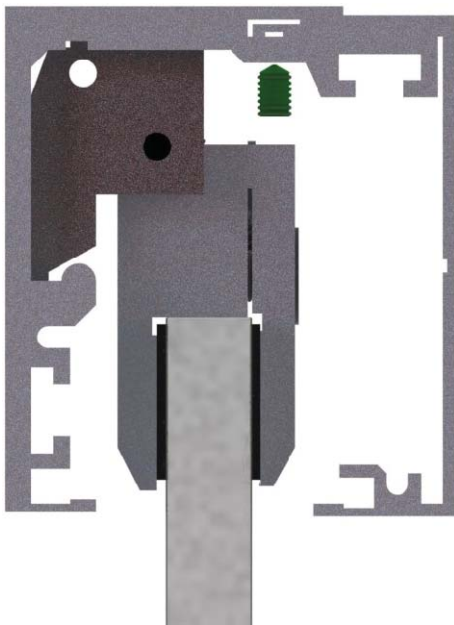

Put the track front cover and secure with **screws** supplied

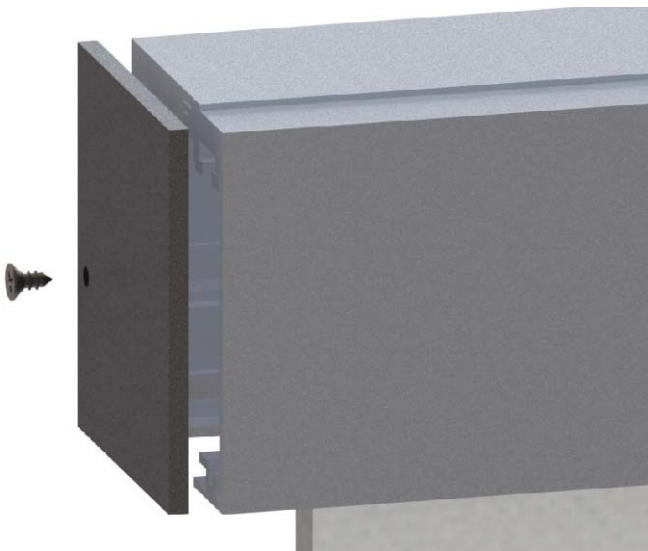

Put end caps into position and secure with screws

FLEXIGLAS 50



Coburn Sliding Systems Limited
Unit 1, Cardinal West, Cardinal Way,
Godmanchester, PE29 2XN, United Kingdom

Phone: +44 (0)20 8545 6680

Fax: +44 (0)20 8545 6720

E-mail: sales@coburn.co.uk

www.coburn.co.uk