

# INSERDOR GLASS DOOR FITTING KIT FITTING INSTRUCTIONS

## NOTE:

Maximum door weight is 80kg without security pins  
and 120kg with security pins

DT – Door thickness, between 8mm and 12mm



61422 – INSERDOR  
GLASS DOOR FITTING KIT

Safety Note : It is recommended to drill  
laminated glass or safety glass before the  
toughening process.

## Step 1 Glass Door Preparation for security pins (for weights over 80kg)

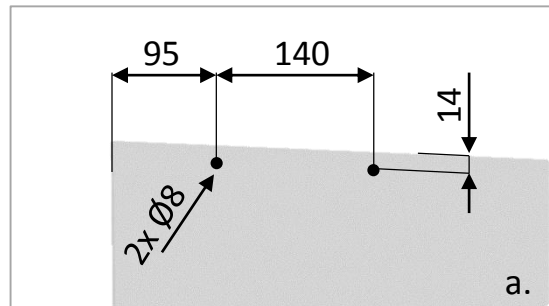
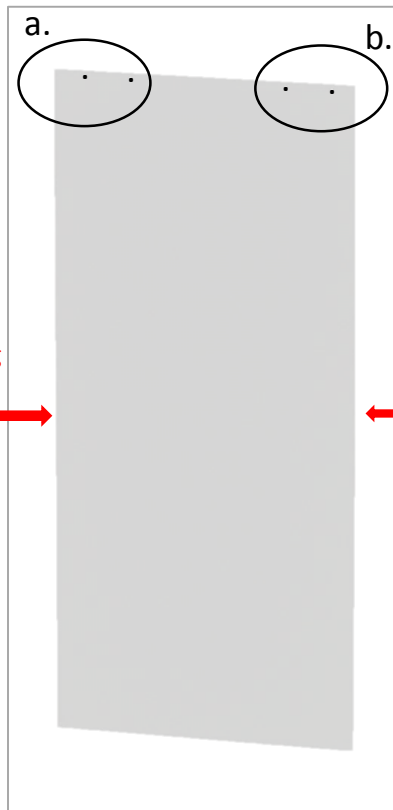

Drill two  $\varnothing 8$ mm holes on the left and two  $\varnothing 8$  on the right  
side of the door. Use dimensions from detail a and b.

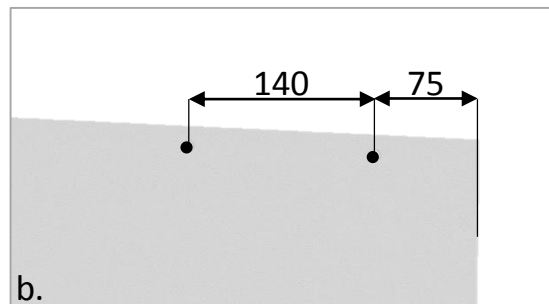

## NOTE:

Pay particular attention and identify the  
pocket and opening side of the door.

# Step 2 Clamp Installation

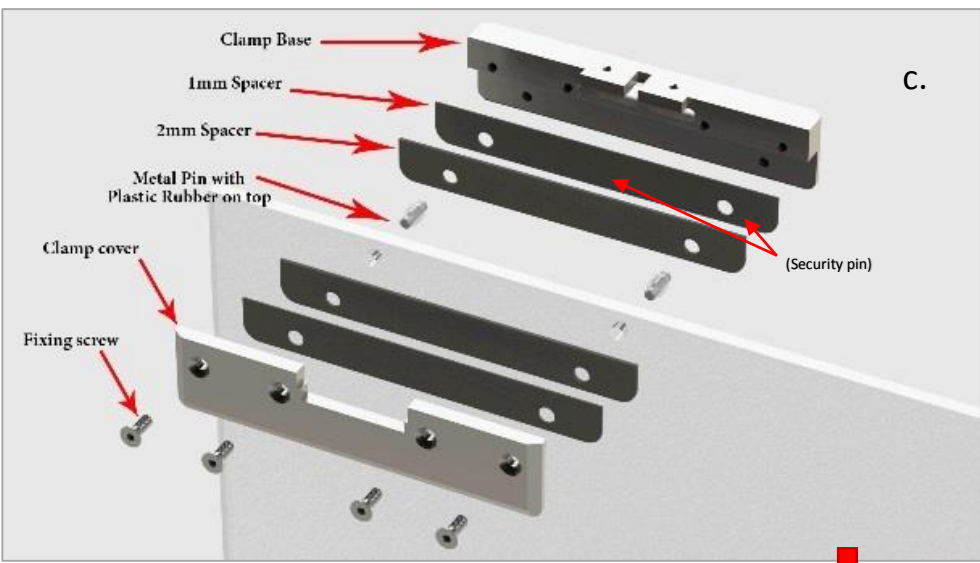
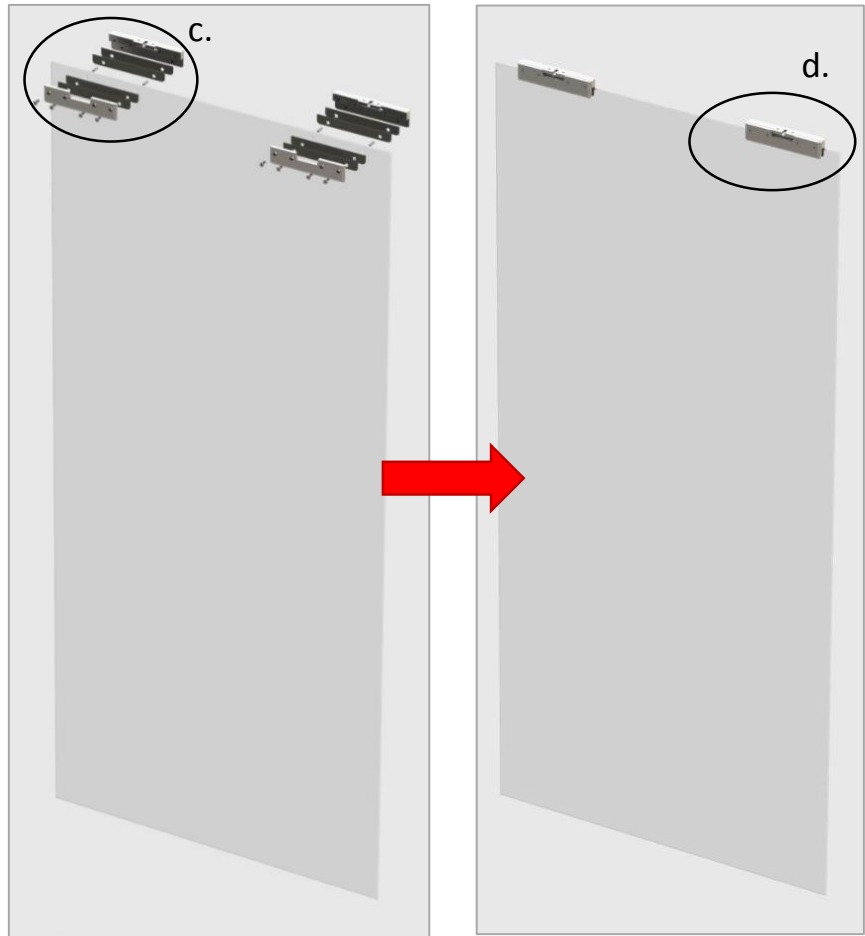

DT=8mm => 2x 2mm spacer  
DT = 10mm => 1x 1mm spacer + 1x 2mm spacer  
DT=12mm => 2x 1mm spacer

Assemble clamps onto door and secure with fixing screws

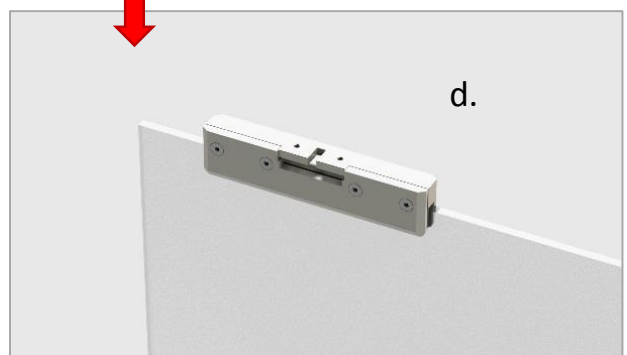

### Step 3 Door Installation

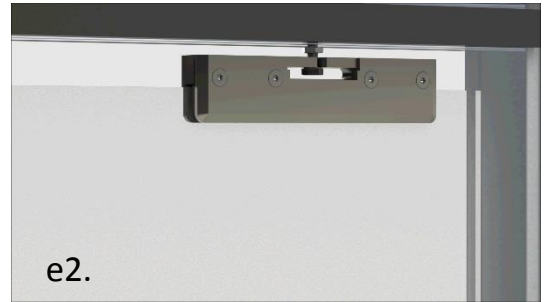
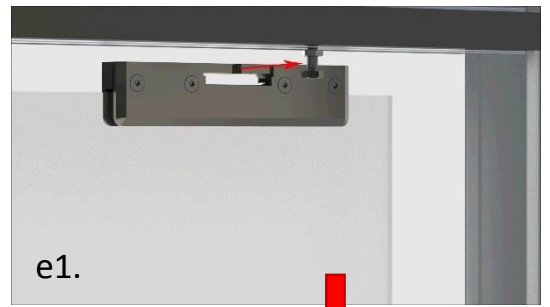

Place both clamps on pendant bolt

### Step 4 Door Adjustment

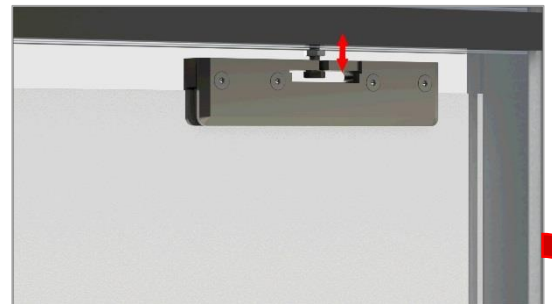

Adjust height and level with pendant bolt.

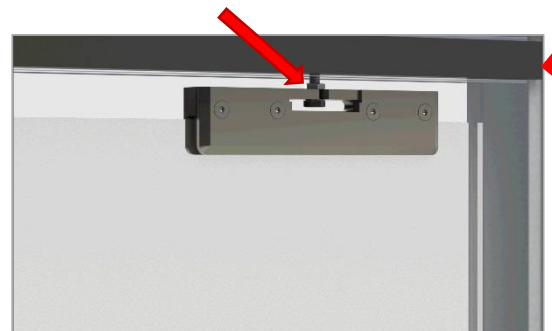

Secure position by tightening nut.

# Step 5 Bottom Guide Installation

B= Big spacer  
S= Small spacer  
DT = Door thickness

DT=8mm => 2x B  
DT = 10mm => 1x S + 1xB  
DT=12mm => 2x S

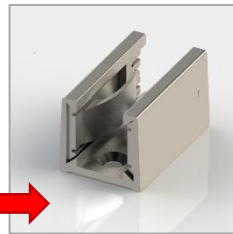

Place guide in position and  
secure with screws

