

DRG No 08-362

DO NOT SCALE

	NAME	DATE
DRN	GERICKE	18.05.04
CHKD		
QA		
ISSUE	MOD No	DATE
01	M3478	20.05.04

7
B /06329.03
459

POLY BAG

8
4/10083.62
459

BAR CODE LABEL

3
A /3868.01
402

4
B /3035.14
402

1
C /3867.02
446

5
B /3028.33
441

2
B /3869.01
440

6
B /3000.90
442

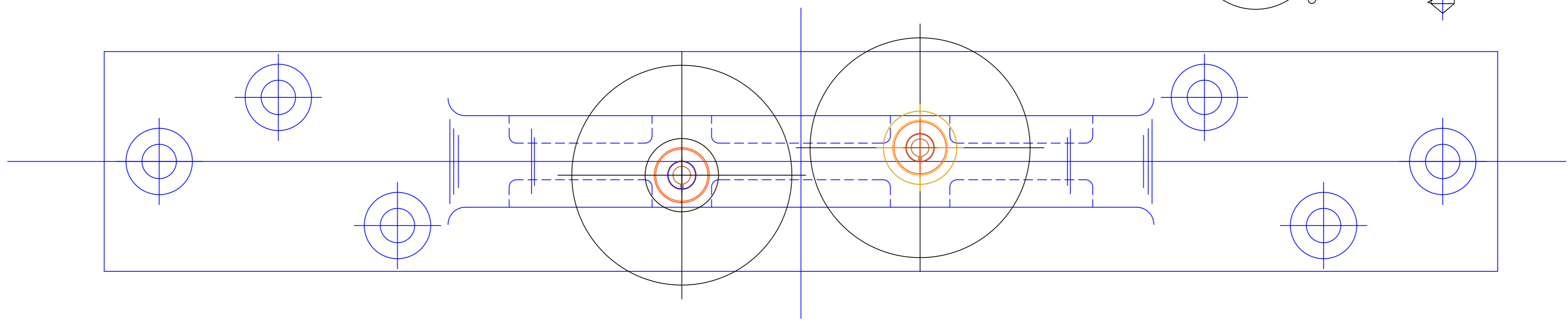
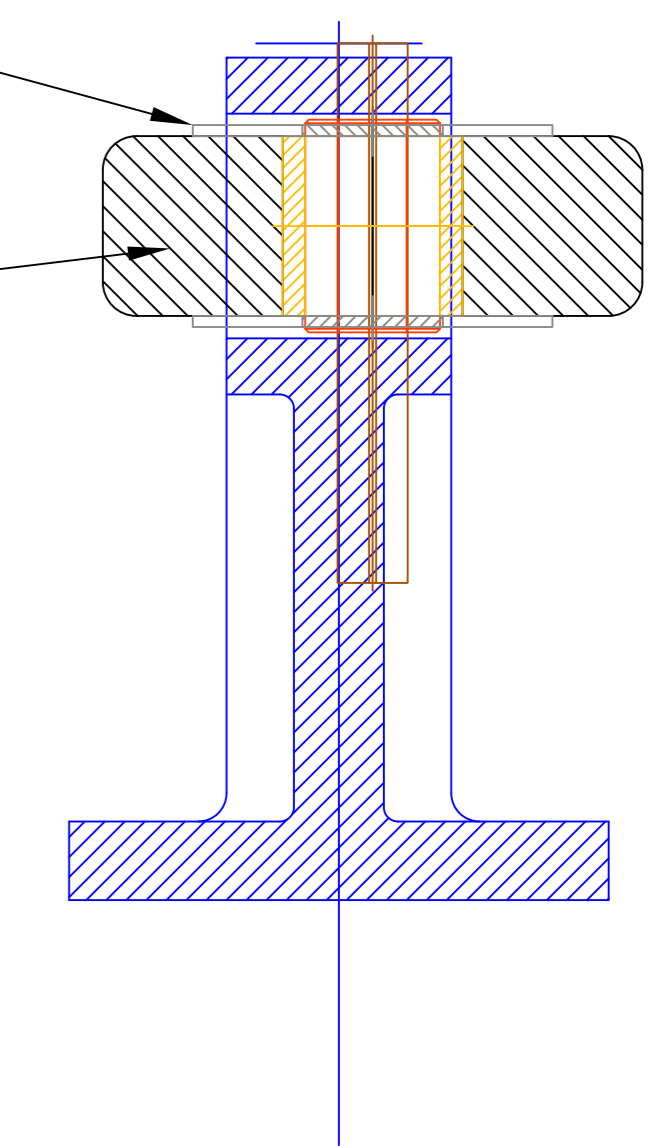
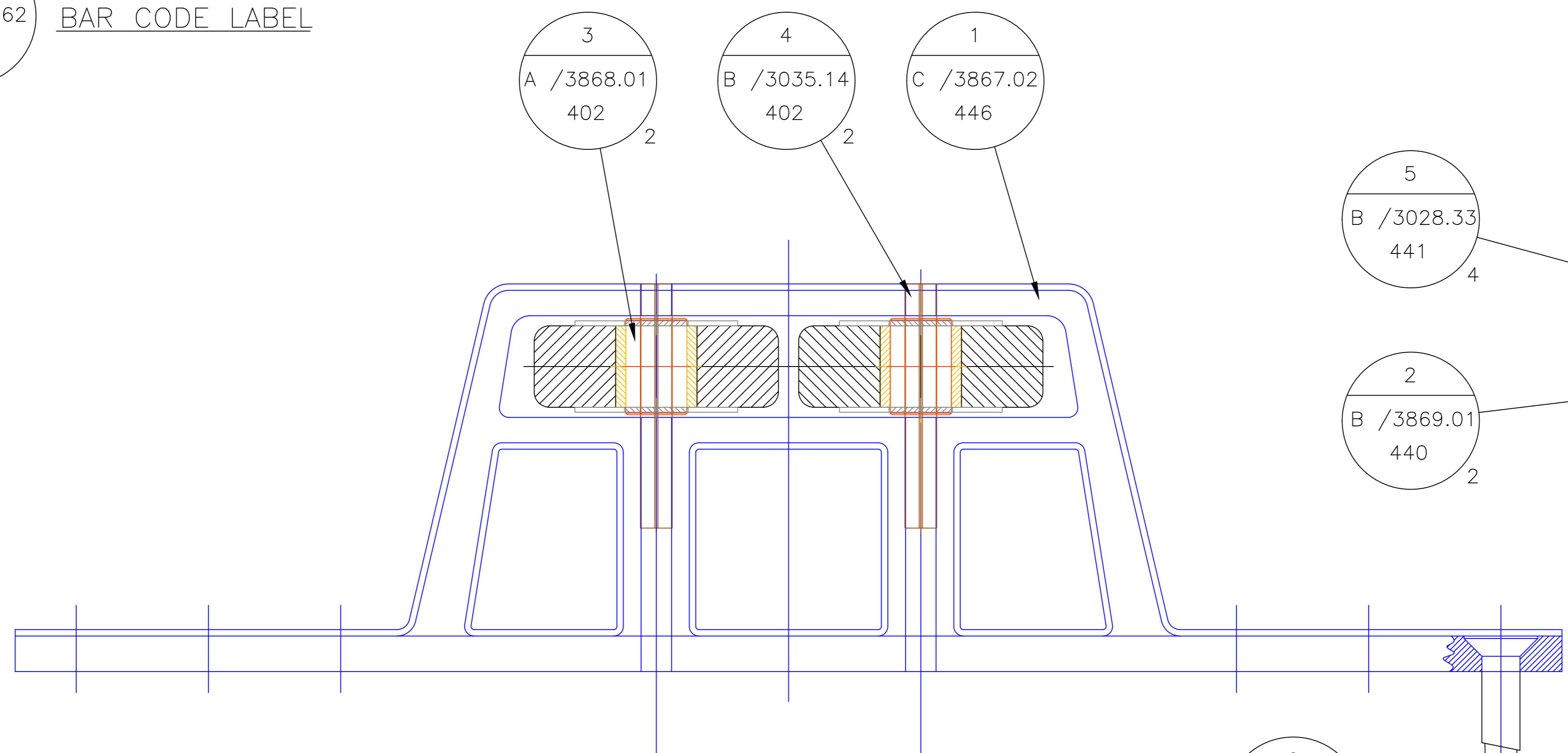
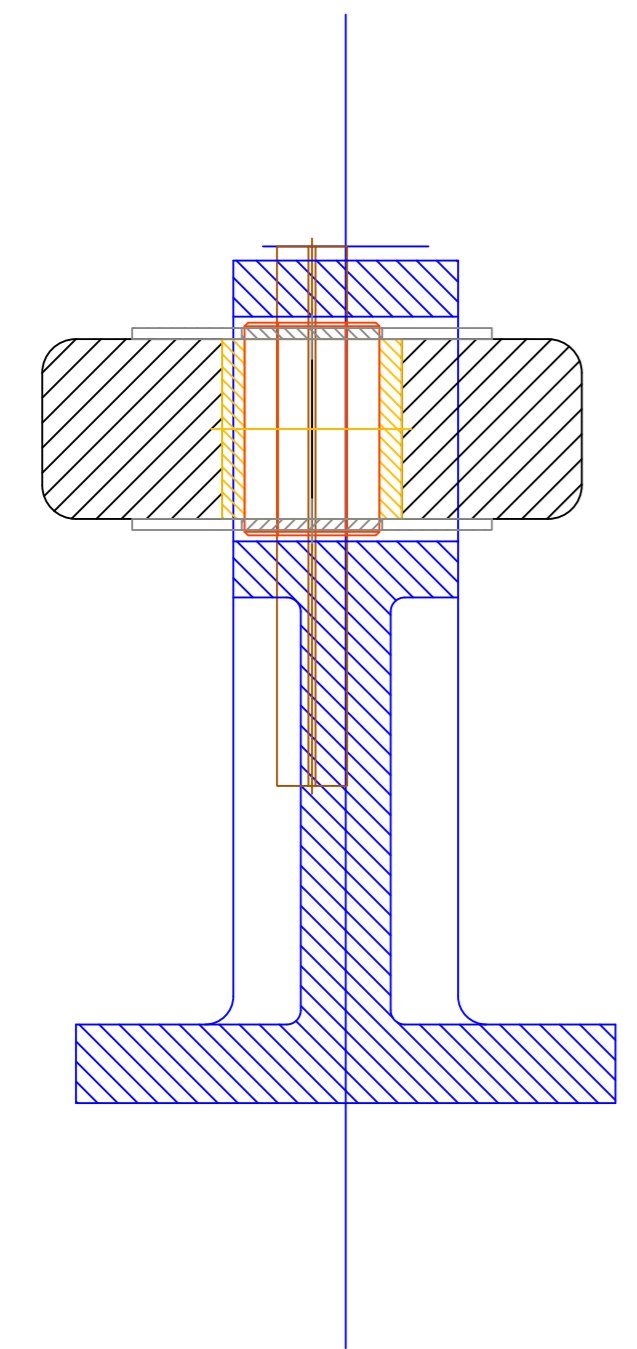

ASSEMBLY INSTRUCTION

1. GREASE WASHER (ITEM 5) AND AXLE (ITEM 3) DURING ASSEM.
2. SPRING DOWEL PIN (ITEM 4) MUST FIT FLUSH INTO FRAME.

PACKING INTRUCTIONS

1. PACK SCREWS (ITEM 6) IN 3"x6" POLY BAGS
2. PACK IN PAIRS.

WAS PT No. C/3960.01



HILLALDAM COBURN LTD
 UNIT 6, WYVERN ESTATE, BEVERLEY WAY,
 NEW MALDEN, SURREY, KT3 4PH, ENGLAND.
 TEL:- 020 8336 1515
 FAX:- 020 8336 1414

CAD FILE No.
 COBURN\08-362.DWG

FINISH

TOLERANCES
 0 Dec Pl ±0.5mm
 1 Dec Pl ±0.2mm
 2 Dec Pl ±0.1mm

SCALE 1:10
 DIMENSIONS IN mm

MATERIAL

HOLES +0.12mm
 ANGLES ±0.5°
 (UNLESS STATED)

COPYRIGHT HILLALDAM COBURN Ltd
 ALL RIGHTS RESERVED
 NO UNAUTHORISED COPYING

TITLE 8-362 TOP GUIDE ASSEMBLY

DRG No 08-362 /102
 A3