

REVISIONS			
REV.	DESCRIPTION	DATE	APPROVED
03	M3699	12/05/2011	B.A

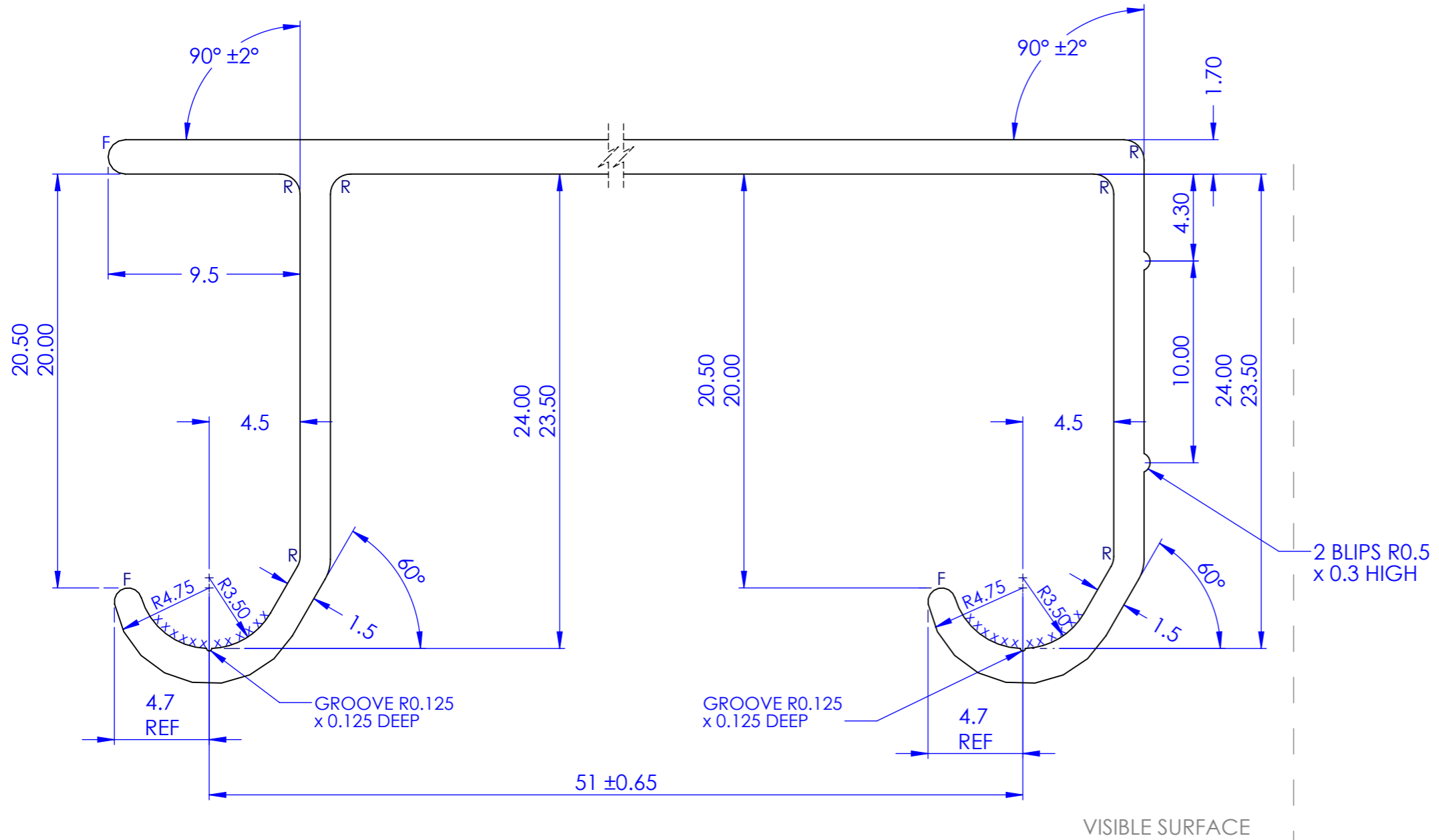

PART No.	LENGTH (mm)
27212	1200
27215	1500
27218	1800
27224	2400

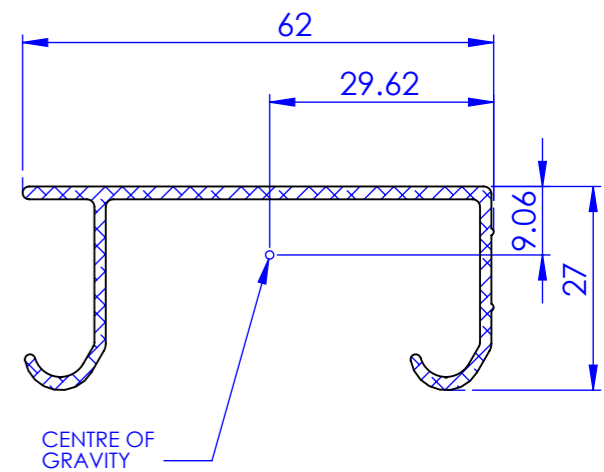

- NOTE**
- F - DENOTES FULL RAD.
  - R - DENOTES 1.0 RAD.
  - UNSPECIFIED WALL THICKNESS 1.5mm ± 0.2.
  - AREA MARKED x x x x TO BE FREE FROM DEFECTS.
  - CUT LENGTHS TO BE AS SPECIFIED TO WITHIN ± 3.0mm.
  - PROPERTIES OF SECTION;  
 AREA - 210.8mm<sup>2</sup>  
 PERIMETER - 259mm  
 APPROX. WEIGHT - 0.569kg/m

<p>HILLDAM COBURN LTD          UNIT 16, MERTON INDUSTRIAL PARK          LEE ROAD, LONDON          SW19 3HX,          UK          TEL:+44 (020) 8545 6680 FAX:+44 (020) 8545 6723          E-Mail:sales@hillaldam.co.uk          Web:www.coburn.co.uk          © COPYRIGHT HILLDAM COBURN LTD</p>	MATERIAL	UNLESS OTHERWISE SPECIFIED:	DRAWN	DATE	FILE DRG. No.
	ALUMINIUM EXTRUSION (6063 T66)	DIMENSION(mm) TOLERANCE ZERO PL DECIMAL ±0.2 ONE PL DECIMAL ±0.1 TWO PL DECIMAL ±0.05	BRYAN.S.A	12/05/2011	3/ 27212-24/ 438
FINISH	ANGULAR TOLERANCE ±0.5°	FORGING TOLERANCE SEE BS 4114	CHECKED	DATE	TITLE:
ANODIZED	COMMENTS: REMOVE ALL SHARP EDGES AND BURRS			12/05/2011	<b>TRACK 27-2 DOUBLE 60X (EXTRA WIDE)</b>
			DIMENSIONS ARE IN mm DO NOT SCALE DRAWING		SIZE
					DRG/PART. No.
					<b>27212-24</b>
					REV
					<b>03</b>
			SCALE: NTS	WEIGHT:	SHEET: 1/1