

REVISIONS			
REV.	DESCRIPTION	DATE	APPROVED
05		19/09/08	E. J
06	M3625	24/09/09	B. S. A

D

C

B

A

4 x ϕ 4.50 THRU ALL
 \sphericalangle ϕ 8.43 X 90°
 PRESS C.S.K

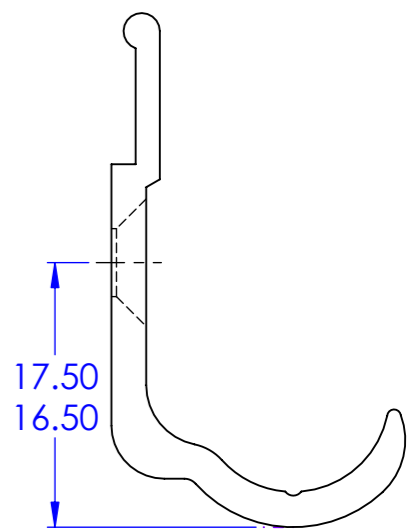
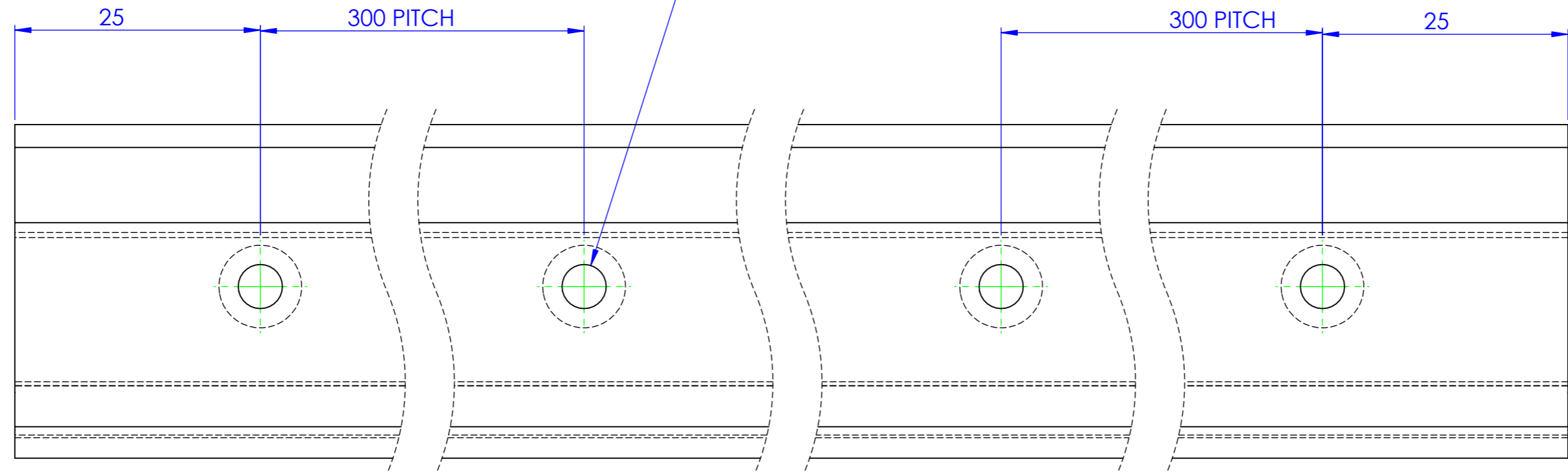

TRACK LENGTH	MATERIAL NUMBER	PART.NO	NUMBER OF HOLES
1200	4/6488.112/438	3/31-1-12/438	5
1500	4/6488.115/438	3/31-1-15/438	6
1800	4/6488.118/438	3/31-1-18/438	7

COBURN
 SLIDING SYSTEMS
 HILLALDAM COBURN LTD
 UNIT 16, MERTON INDUSTRIAL PARK
 LEE ROAD, LONDON
 SW19 3HX,
 UK
 COPYRIGHT HILLALDAM COBURN LTD
 THE INFORMATION CONTAINED IN THIS DRAWING IS THE SOLE PROPERTY OF <HILLALDAM COBURN LTD>. ANY REPRODUCTION IN PART OR AS A WHOLE WITHOUT THE WRITTEN PERMISSION OF <HILLALDAM COBURN LTD> IS PROHIBITED.

MATERIAL	UNLESS OTHERWISE SPECIFIED: DIMENSIONS ARE IN MM	NAME	DATE	CAD FILE:
SEE TABLE <td rowspan="3">TOLERANCES: FRACTIONAL \pm ANGULAR: MACH \pm0.5 BEND \pm ZERO PLACE DECIMAL \pm 0.2 ONE PLACE DECIMAL \pm0.1 TWO PLACE DECIMAL \pm0.05</td> <td>DRAWN</td> <td>E. JOHNSON</td> <td>19/09/08</td>	TOLERANCES: FRACTIONAL \pm ANGULAR: MACH \pm 0.5 BEND \pm ZERO PLACE DECIMAL \pm 0.2 ONE PLACE DECIMAL \pm 0.1 TWO PLACE DECIMAL \pm 0.05	DRAWN	E. JOHNSON	19/09/08
FINISH		CHK	BRYAN. S. A	24/09/09
SELF COLOUR		Q.A.		
APPLICATION	DO NOT SCALE DRAWING	COMMENTS: REMOVE ALL SHARP EDGES		TITLE: HOUSE 1 MKII TRACK MACHINED LENGTHS
		SIZE	DWG. NO.	REV
		A3	31112-31118	06
		SCALE: 2:1	WEIGHT:	SHEET 1 OF 1