

58
COBURN 4-30
MADE IN ENGLAND

IDENTIFICATION MARK
 STAMPED ON TOP OF TRACK
 TO SUIT DIAMETER OF ROLLS

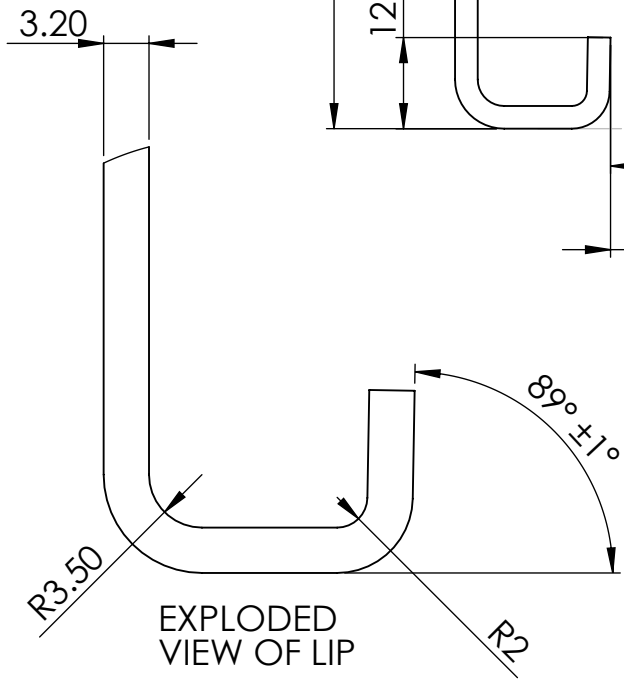
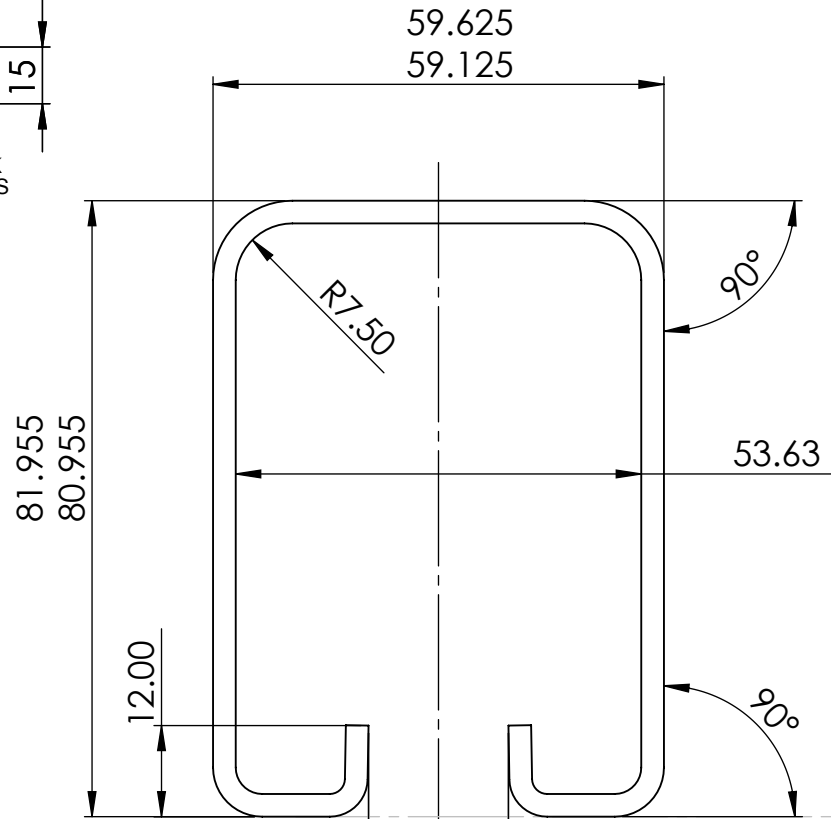

NOTE:
 LENGTHS TO BE SUPPLIED STRAIGHT AND FREE FROM TWIST.
 ALLOWABLE FLARE TOLERANCES AT END, TRAILING STRUCK END ^{60.0} 59.0°, LEADING
 END ^{60.0} 59.0°
 MATERIAL; PRIME BRIGHT SPANGLED GALVANISED MILD STEEL SLIT COIL 3.2mm ±0.25 THICK
 STRIP, EN 10142 Fe PO2G Z 275 N A C.
 TO BE FREE FROM WHITE RUST & OTHER DEFECTS.

REVISIONS			
REV.	DESCRIPTION	DATE	APPROVED
07			
08	M3326	22/06/98	
09	M3483	27/05/04	S. K
10	M3713	28/03/11	B. S. A

DO NOT SCALE DIMENSIONS IN mm FILE DRG No. C /43018-30 /438



UNLESS OTHERWISE SPECIFIED:

DIMENSION(mm)	TOLERANCE
ZERO PL DECIMAL	±0.2
ONE PL DECIMAL	±0.1
TWO PL DECIMAL	±0.05

ANGULAR TOLERANCE ±1.0°

FORGING TOLERANCE SEE BS 4114

LIPS MUST BE LEVEL

PART No.	LENGTH (mm)
43018	1800
43021	2100
43024	2400
43030	3000



HILLDAM COBURN LTD
 UNIT 16, MERTON INDUSTRIAL PK
 LEE ROAD, LONDON
 SW19 3HX, ENGLAND
 TEL: +44 (0)20 8545 6680
 FAX: +44 (0)20 8545 6723
 e-mail: sales@hillaldam.co.uk
 www.coburn.co.uk

COPYRIGHT HILLDAM COBURN LTD ©
 THE INFORMATION CONTAINED IN THIS DRAWING IS THE SOLE PROPERTY OF <HILLDAM COBURN LTD>. ANY REPRODUCTION IN PART OR AS A WHOLE WITHOUT THE WRITTEN PERMISSION OF <HILLDAM COBURN LTD> IS PROHIBITED.

TITLE
STANDARD LENGTH TRACK 4-30

MATERIAL
 SEE NOTE

FINISH
 SELF COLOUR

DRAWN BRYAN.S.A DATE 28/03/2011

CHECKED DATE 05/04/2011

SCALE:1:1, 2:1 SIZE: A4 SHEET:1/1

DRG/PART. No. **43018-30** ISSUE 10

REMOVE ALL BURRS AND SHARP EDGES