

Revisions			
Rev	Modification No	Date	Approved
01	M-3828	21/05/13	MUS

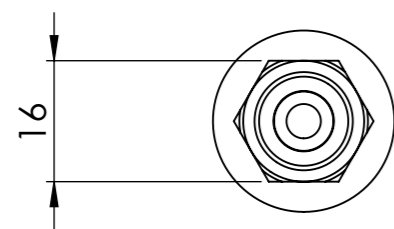

ITEM NO.	PART NUMBER	DESCRIPTION	QTY.
1	44319.01	16 ROLLER GUIDE FOR METAL DOOR	2
2	03026.112	M12 STATITE LOCK NUT	2
3	03028.121	BRIGHT WASHER M12 (FORM B)	2
1	06326.04	Poly bag	1

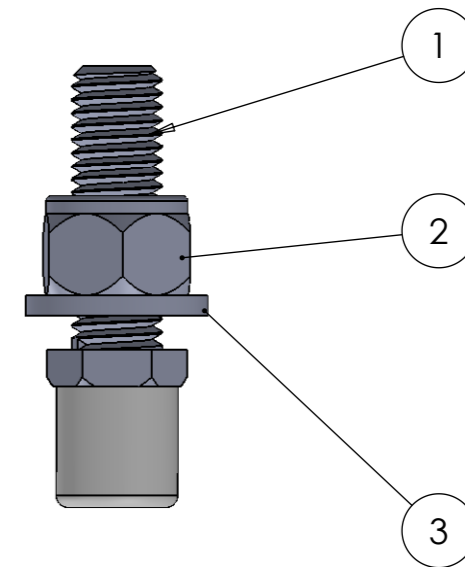
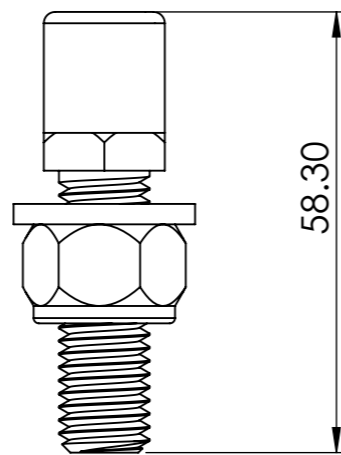
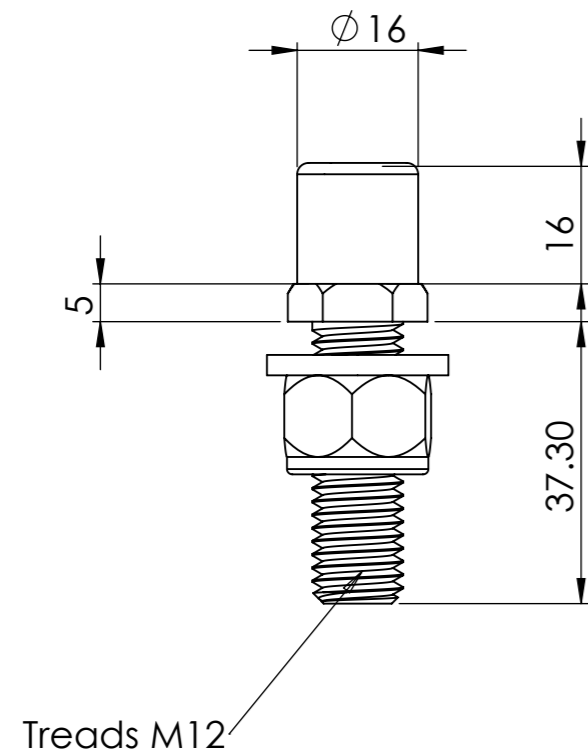

HILLALDAM COBURN LTD
 UNIT 16, MERTON INDUSTRIAL PARK
 LEE ROAD, LONDON
 SW19 3HX,
 UK
 TEL:+44 (02)0 8545 6680 FAX:+44 (02)0 8545 6723
 E-Mail:sales@hillaldam.co.uk
 Web:www.coburn.co.uk

MATERIAL Steel / Nylon	UNLESS OTHERWISE SPECIFIED: DIMENSION(mm) TOLERANCE ZERO PL DECIMAL ±0.8 ONE PL DECIMAL ±0.5 TWO PL DECIMAL ±0.08	DRAWN MUS	DATE 21/05/2013	FILE DRG. No. 1/44319/
FINISH Zinc Plate		CHECKED MUS	DATE 21/05/2013	TITLE: Guide for Metal door Straightaway 250
COPYRIGHT HILLALDAM COBURN LTD © THE INFORMATION CONTAINED IN THIS DRAWING IS THE SOLE PROPERTY OF <HILLALDAM COBURN LTD>. ANY REPRODUCTION IN PART OR AS A WHOLE WITHOUT THE WRITTEN PERMISSION OF <HILLALDAM COBURN LTD> IS PROHIBITED.	ANGULAR TOLERANCE ±0.5° FORGING TOLERANCE SEE BS 4114	DIMENSIONS ARE IN mm DO NOT SCALE DRAWING		SIZE A4
COMMENTS: REMOVE ALL SHARP EDGES AND BURRS		DRG/PART. No. 44319		REV 01
		SCALE: NTS	WEIGHT:	SHEET: 1/1