

Scale: 1:3

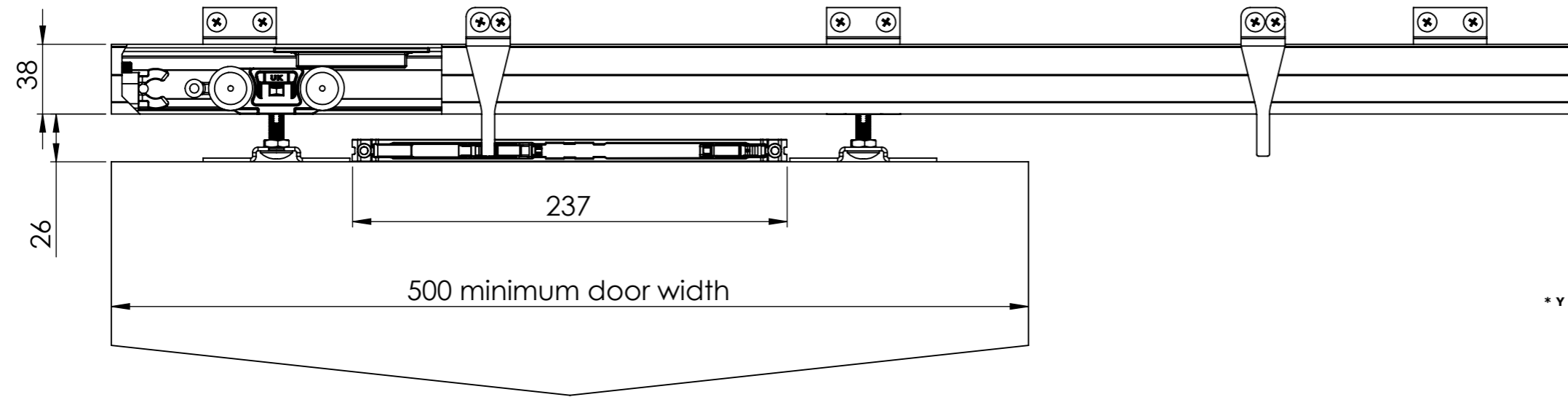

(Y) dimension depends on thickness of the door, can be adjusted according to door thickness please see table A

* Y = gap between damper and door edge

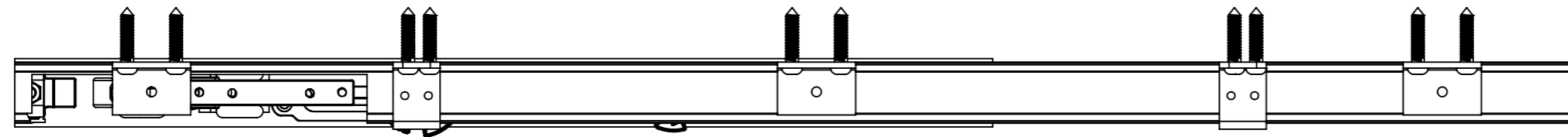
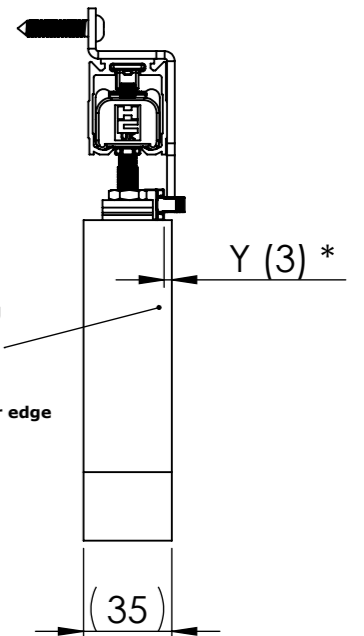

Door	Y (mm)
20	-3
25	0
30	1.5
35	3
40	5.5
45	7.5
50	10

<p>COBURN SLIDING SYSTEMS LTD UNIT 1, CARDINAL WEST CARDINAL WAY, GODMANCHESTER PE29 7BJ, UK TEL:+44 (02)0 8545 6680 FAX:+44 (02)0 8545 6723 E-Mail:sales@coburn.co.uk Web:www.coburn.co.uk © COPYRIGHT COBURN SLIDING SYSTEMS LTD</p> <p>THE INFORMATION CONTAINED IN THIS DRAWING IS THE SOLE PROPERTY OF <COBURN SLIDING SYSTEMS LTD>. ANY REPRODUCTION IN PART OR AS A WHOLE WITHOUT THE WRITTEN PERMISSION OF <COBURN SLIDING SYSTEMS LTD> IS PROHIBITED.</p>	MATERIAL	<p>UNLESS OTHERWISE SPECIFIED:</p> <p>DIMENSION(mm) TOLERANCE ZERO PL DECIMAL ±0.2 ONE PL DECIMAL ±0.1 TWO PL DECIMAL ±0.05</p> <p>ANGULAR TOLERANCE ±0.5°</p> <p>FORGING TOLERANCE SEE BS 4114</p> <p>COMMENTS: REMOVE ALL SHARP EDGES AND BURRS</p>	<p>DRAWN DATE MUS 21.01.2020</p> <p>CHECKED DATE</p> <p> DIMENSIONS ARE IN mm DO NOT SCALE DRAWING</p>	FILE DRG. No.						
	FINISH			TITLE: Softcloser ST-100						
				<table border="1"> <tr> <td>SIZE</td> <td>DRG/PART. No.</td> <td>REV</td> </tr> <tr> <td>A4</td> <td>30654 -55-56</td> <td>01</td> </tr> </table>	SIZE	DRG/PART. No.	REV	A4	30654 -55-56	01
SIZE	DRG/PART. No.	REV								
A4	30654 -55-56	01								
				<table border="1"> <tr> <td>SCALE: NTS</td> <td>WEIGHT:</td> <td>SHEET: 1/1</td> </tr> </table>	SCALE: NTS	WEIGHT:	SHEET: 1/1			
SCALE: NTS	WEIGHT:	SHEET: 1/1								