



FOLDASIDE 150

FITTING INSTRUCTIONS

PART NUMBER : 06427.34



Coburn Sliding Systems Limited, Cardinal West, Cardinal Way, Godmanchester, PE29 2XN, UK



sales@coburn.co.uk



www.Coburn.co.uk



+44(0)208545 6680

SYSTEM DRAWING AND PARTS

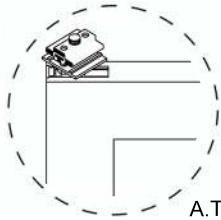

A. Top Pivot

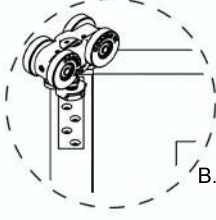

B. 4 Wheel Hanger

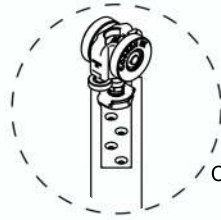

C. 2 Wheel Hanger

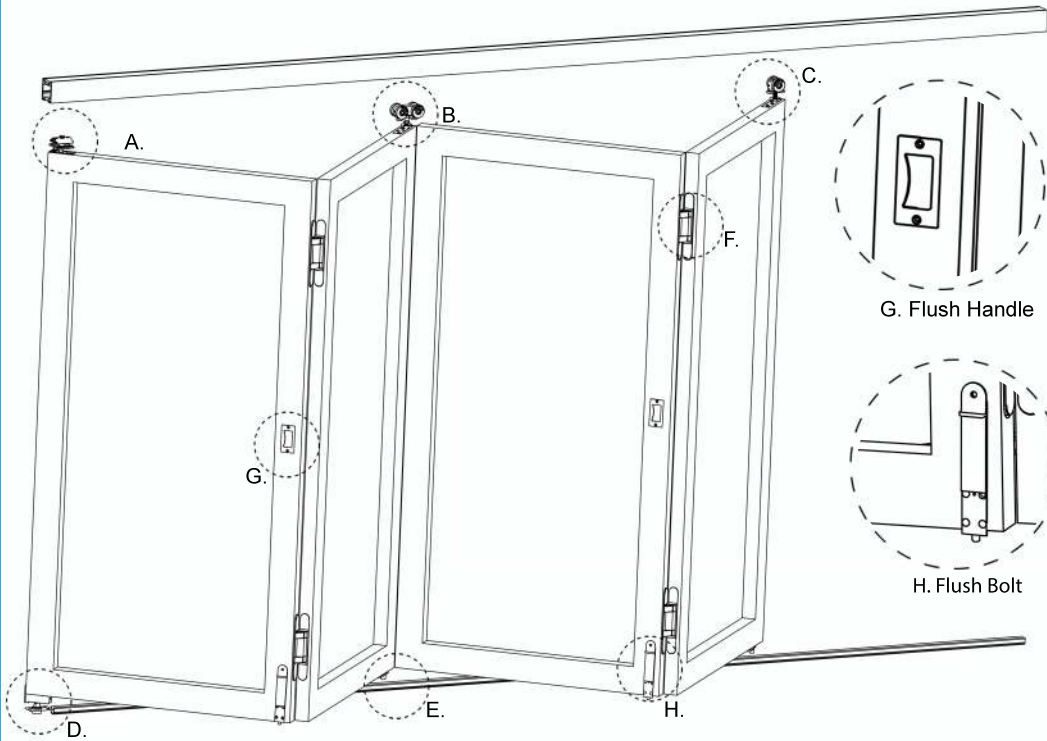

G. Flush Handle

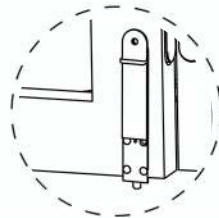

H. Flush Bolt

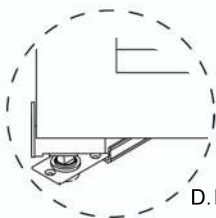

D. Bottom Pivot

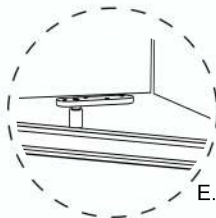

E. Bottom Guide

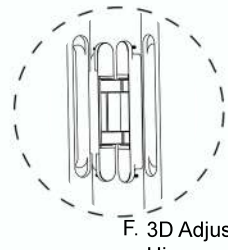

F. 3D Adjustable Hinge

SECTION VIEWS

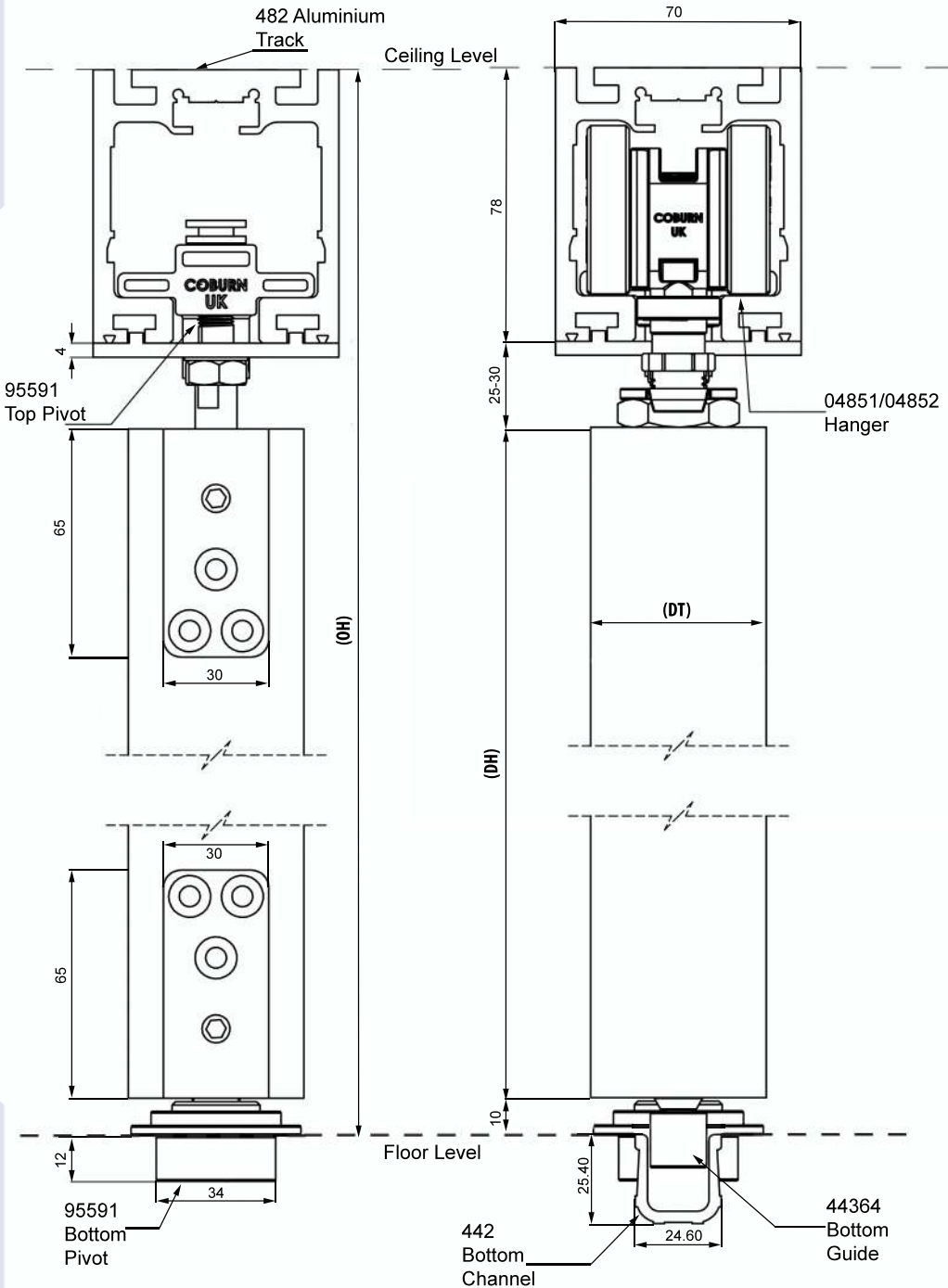

STANDARD VIEWS

Top View

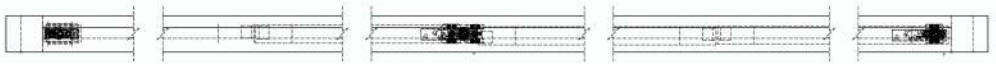

Front view

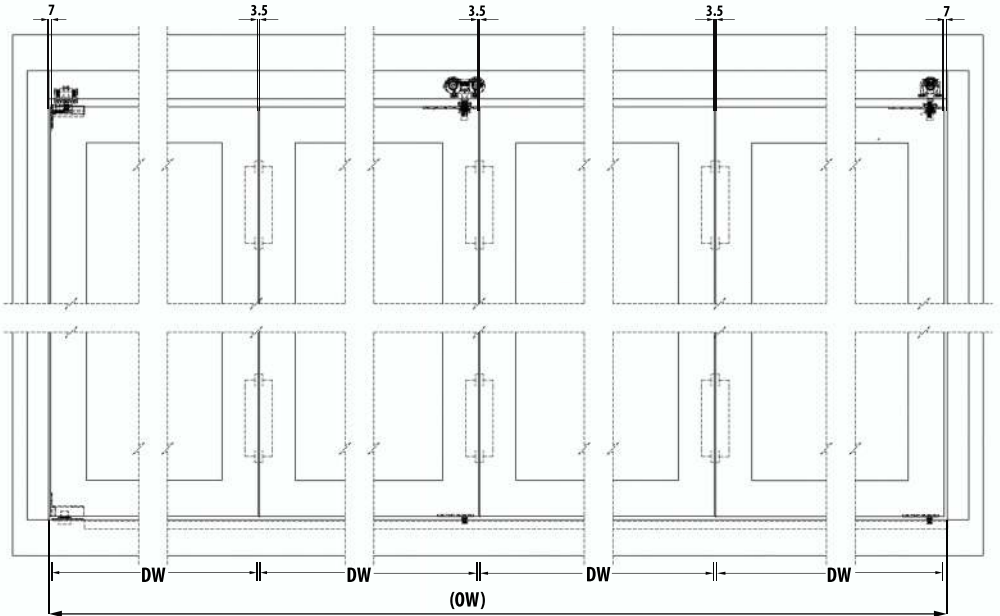

Maximum Door Weight
150 Kg (22 lbs)



Maximum Door Width
1500mm (4'11")



Door Thickness
**42-65mm
(1 2/3" to 2 5/9")**

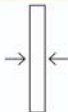

Maximum Door Height
4500mm (14'9")

$OW = 4 (DW) + 3.5 (\text{No. of Doors} - 1) + 14$

DH = Door height

Dw = Door width

DT = Door thickness

OW = Opening width

OH = Opening height

Assembly

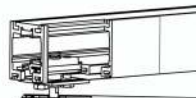

Top pivot assembly into the track with the door

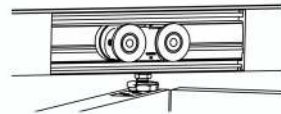

Wheel hanger assembly into the track with the door

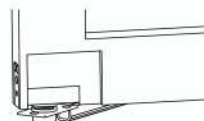

Bottom pivot assembly with the door and channel

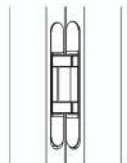

3D adjustable hinge assembled between two doors.

4 Door Configuration

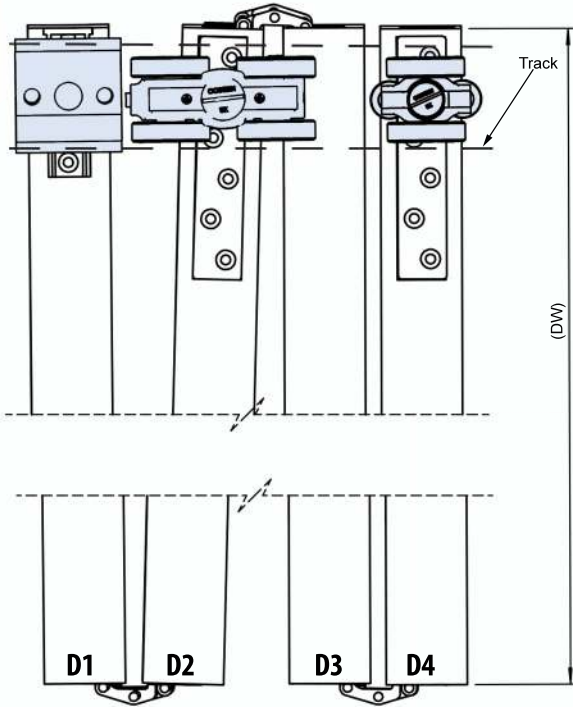

Door Configurations

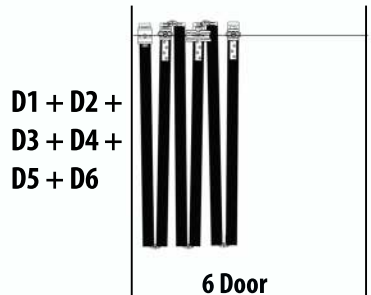
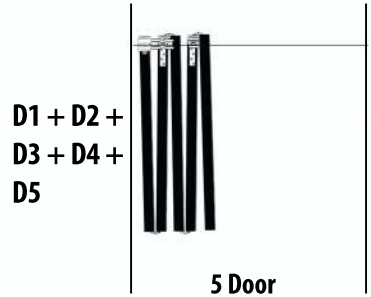
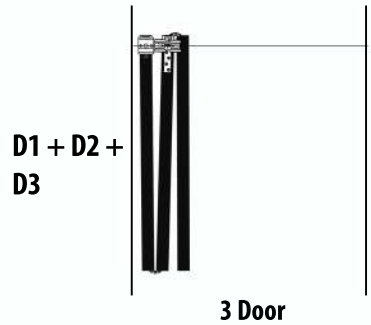
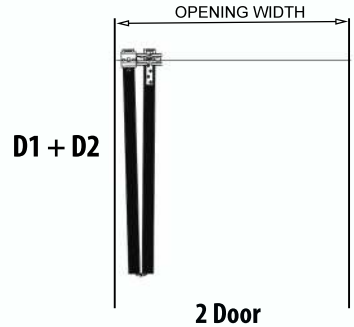

Installation Configuration

Installation with or without a bottom guide/channel



Installation with a bottom guide/channel

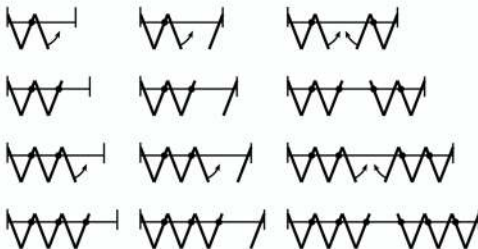

COMPONENTS LIST



TOOLS REQUIRED

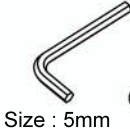

STEP 1

- SOFFIT FIXING

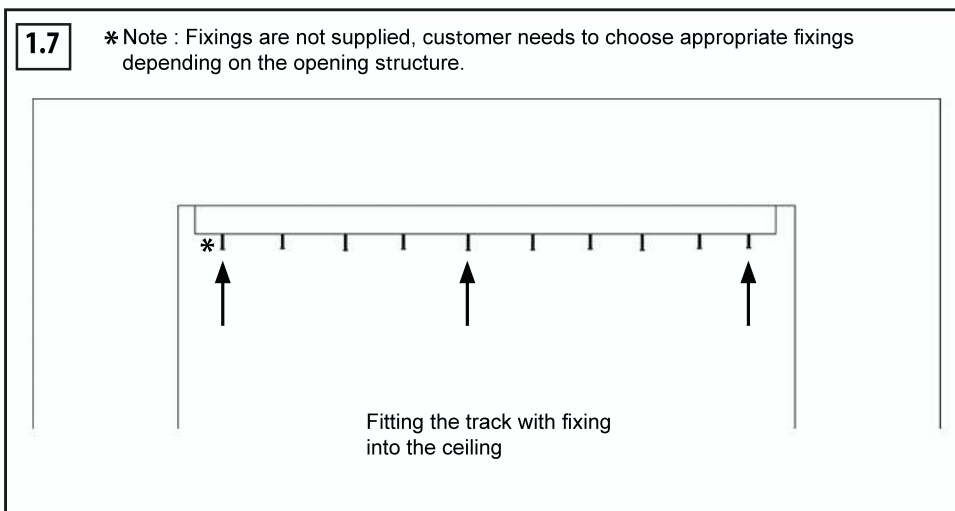
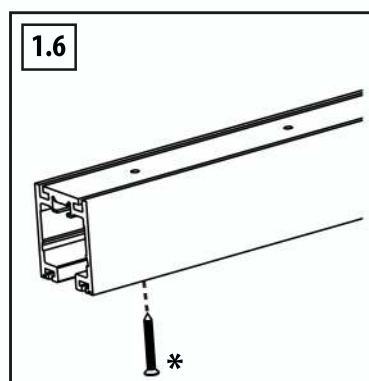
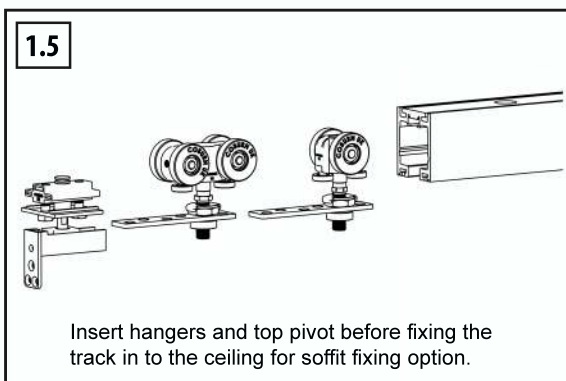
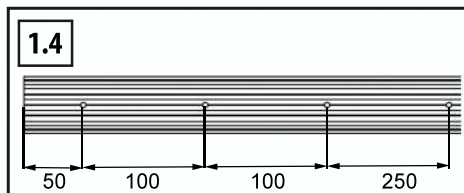
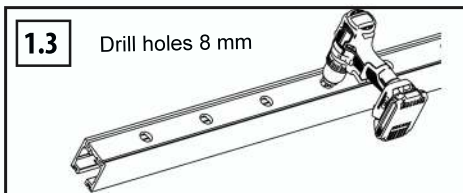
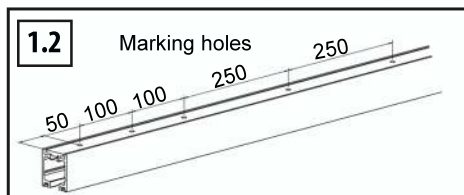
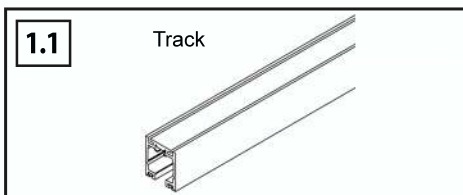

STEP 2 - SIDE FIXING

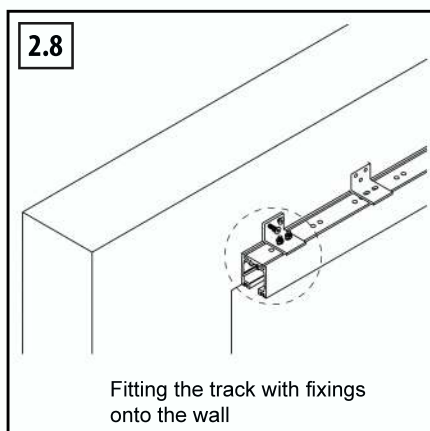
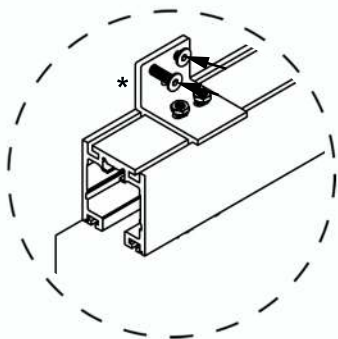
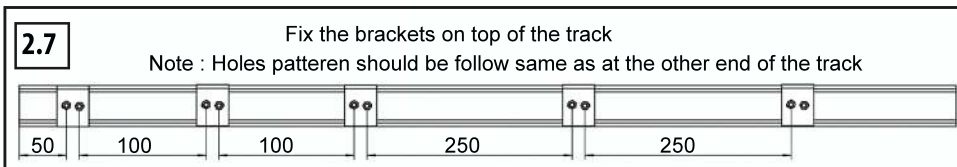
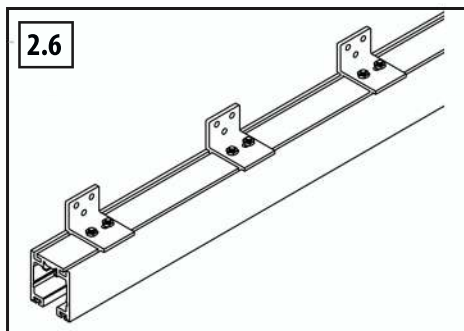
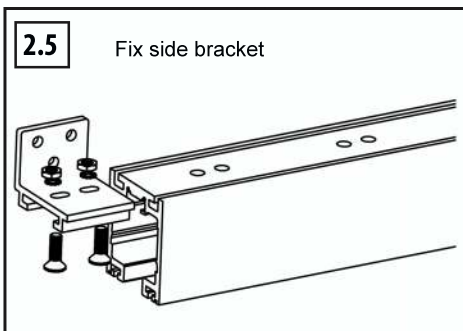
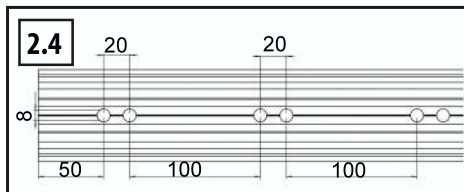
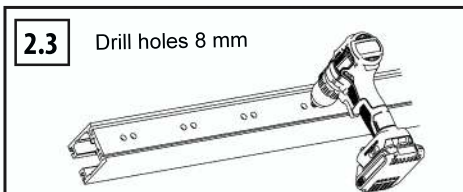
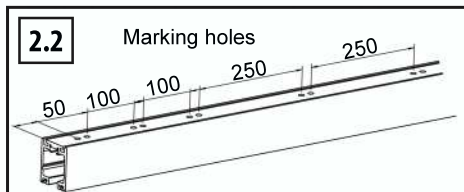
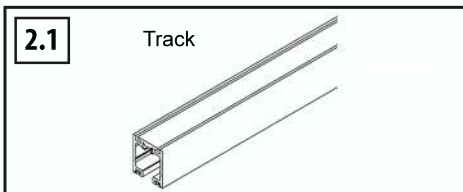

* Note : Fixings are not supplied, customer needs to choose appropriate fixings depending on the opening structure.

04852 - 4 Wheel Hanger

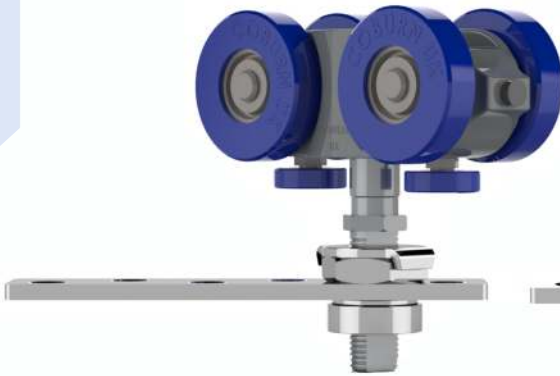

04851 - 2 Wheel Hanger

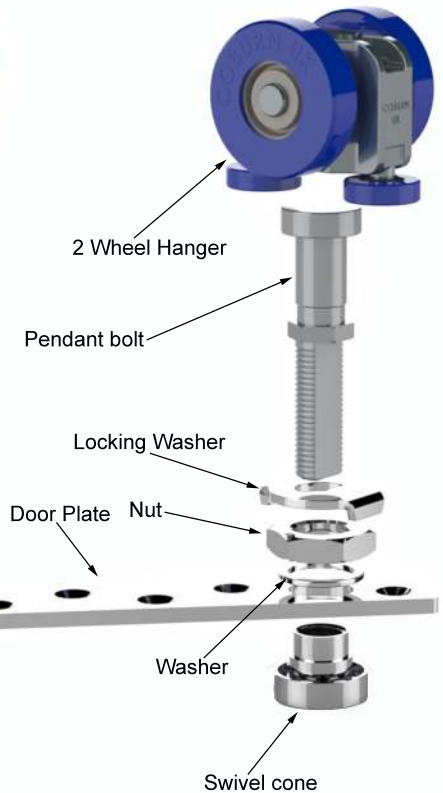
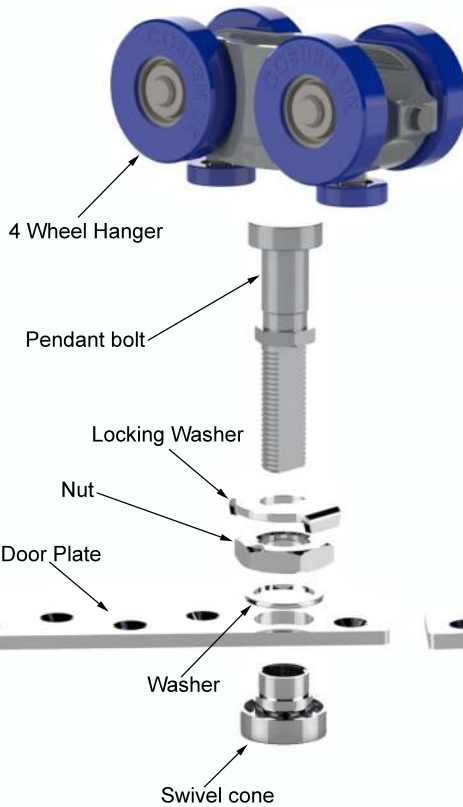

STEP 3

3.2 - IDENTIFYING PIVOT SET



Top Pivot



Bottom Pivot

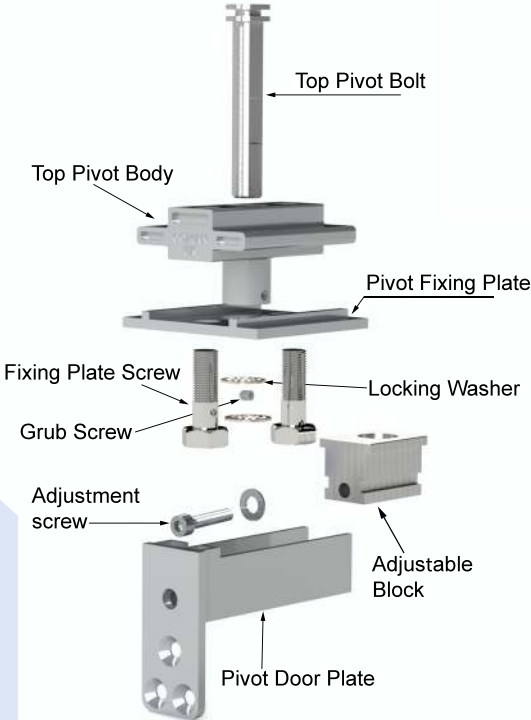



3D Adjustable Hinge



Section View



← Cover



← Hinge Body



PIVOT SET CUT-OUT DETAILS

Top Pivot Plate Cut-out

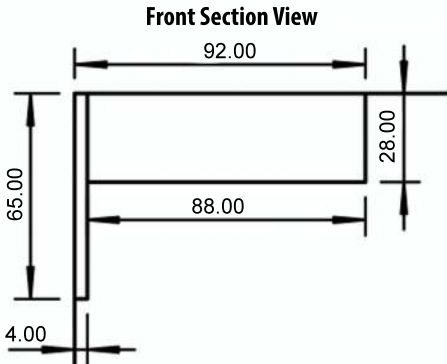

Side View

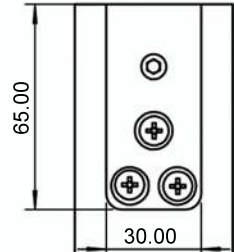

Top View

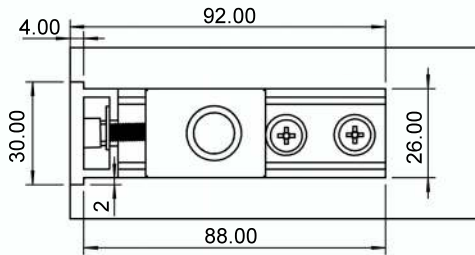

Bottom Pivot Plate Cut-out

Top View

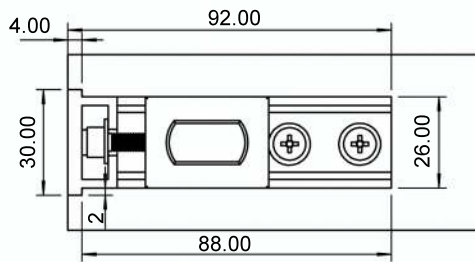

Door Side View

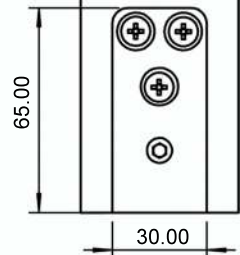

Front Section View

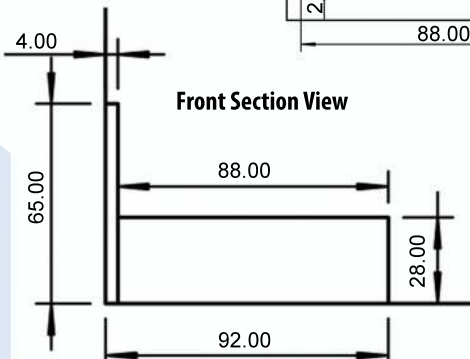

HINGE CUT-OUT DETAILS

Front view

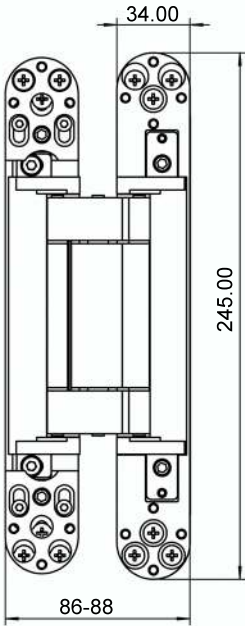

Side view

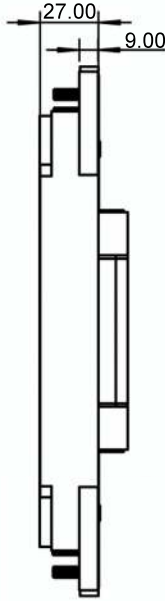

Top view

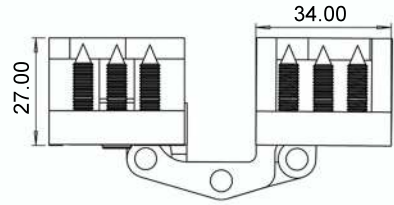

Cut-out top view

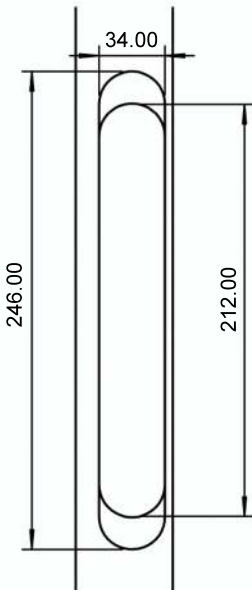

Cut-out Section view

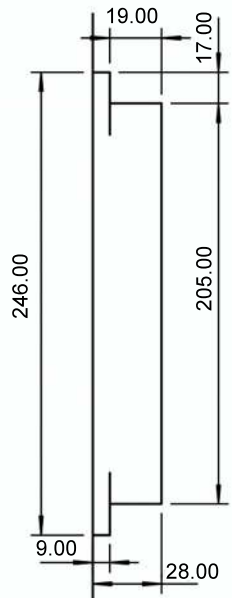

Hanger Plate Cut-Out

Front Section View

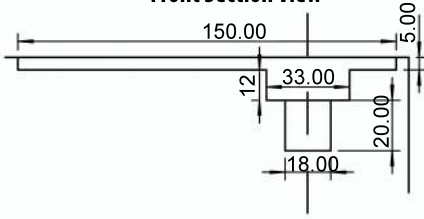

Hanger Plate Side View



Top View

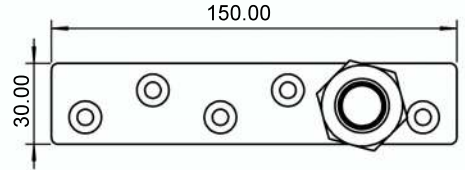
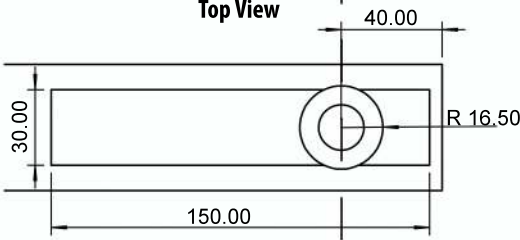

Bottom Guide Cut-Out

Front Section View

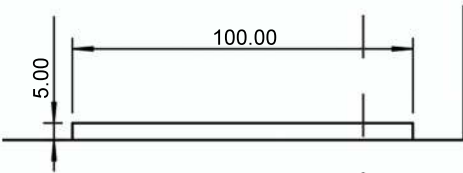

Bottom Guide Side View

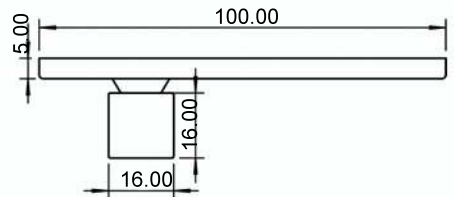

Top View

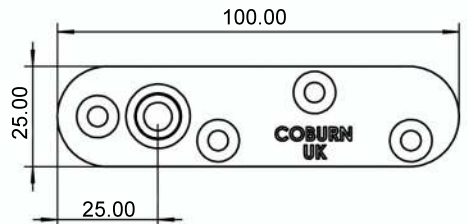
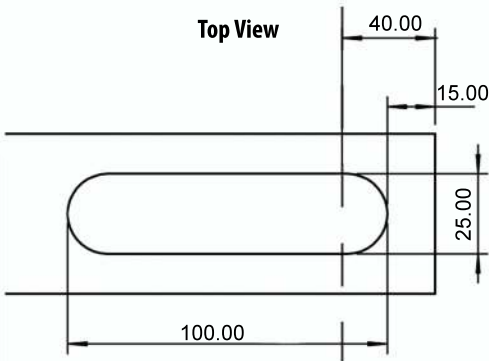

STEP 4

DOOR ASSEMBLY - DOOR 1

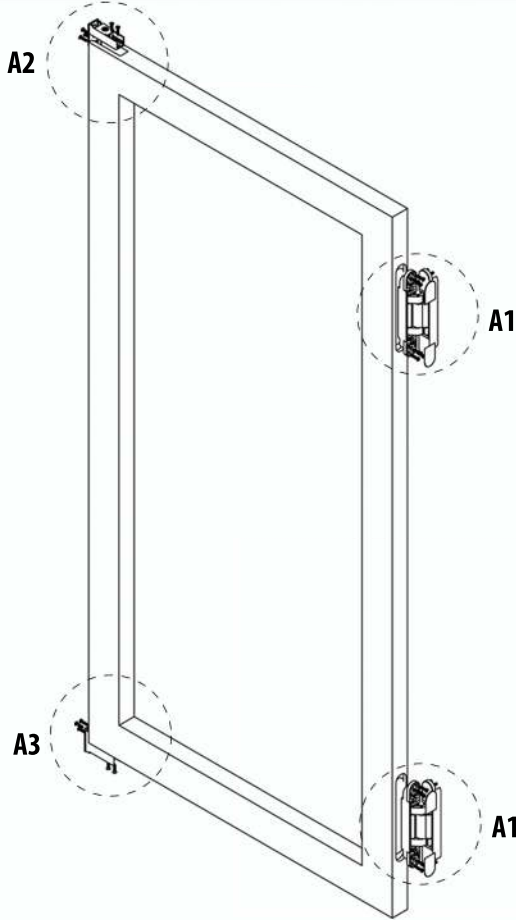

Door 1 (D1) - Parts :

1. 95555 Hinges x 2
2. 95591 Top Pivot x 1
3. 95591 Bottom Pivot x 1

A1 - 3D Adjustable Hinge

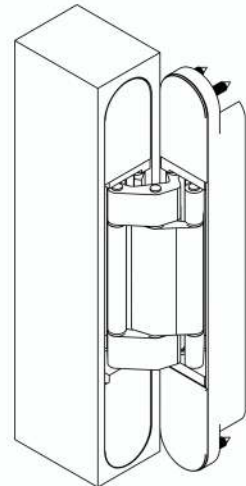
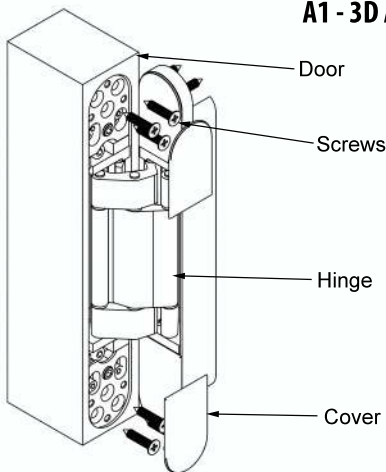



A2 - Top Pivot Door Plate

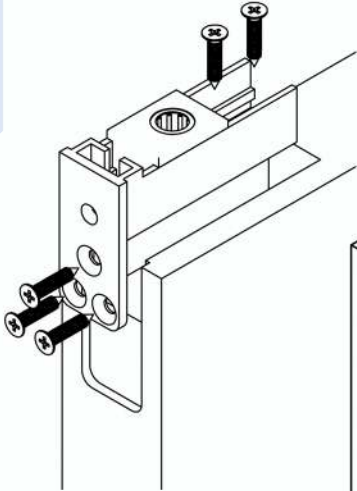

A2.1

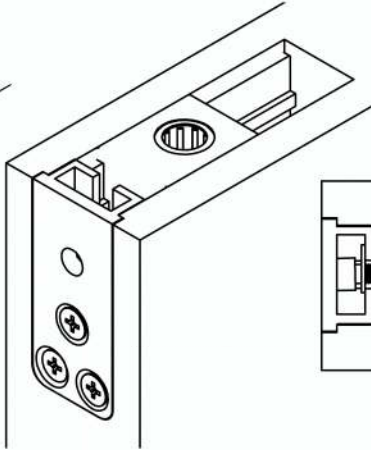

A2.2

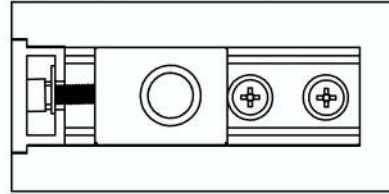

A2.3

A3 - Bottom Pivot Door Plate

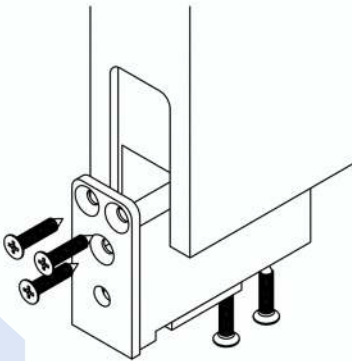

A3.1

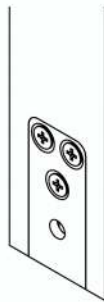

A3.2

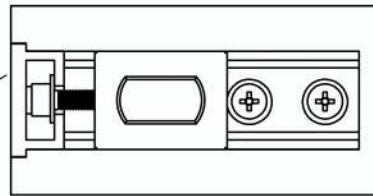

A3.3



STEP 4

DOOR ASSEMBLY - DOOR 2

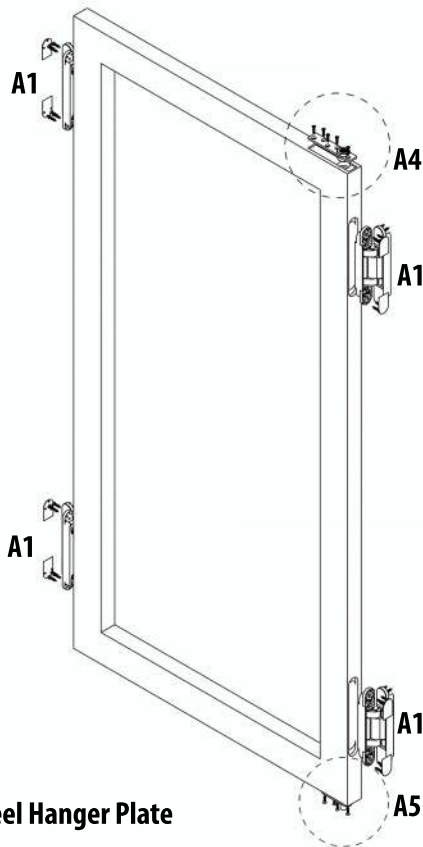

Door 2 (D2) - Parts :

1. 95555 Hinges x 4
2. 04852 Hanger x 1
3. 44364 Guide x 1

A4 - Wheel Hanger Plate

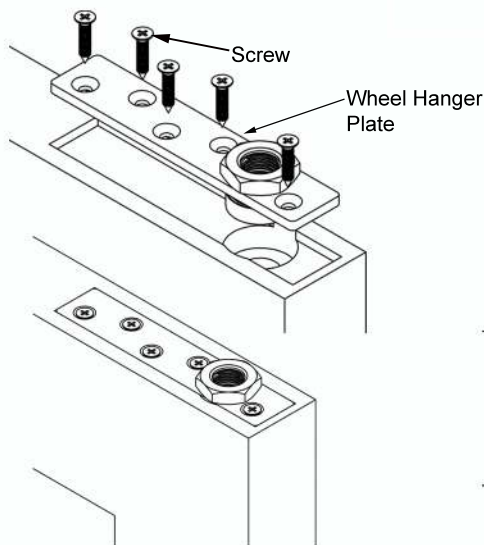

A5 - Bottom Guide

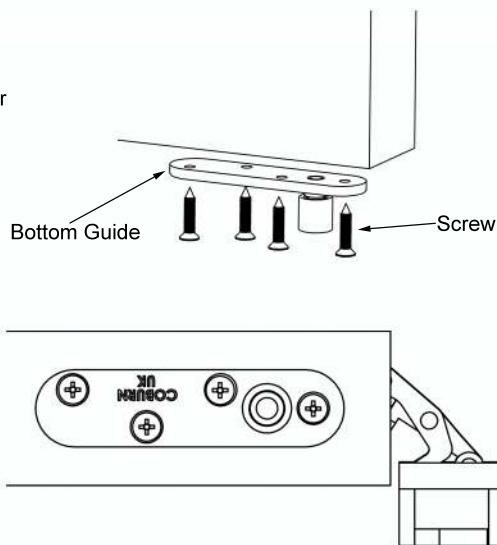

STEP 4

DOOR ASSEMBLY - DOOR 3



Door 3 (D3) - Parts :

1. 95555 Hinges x 4

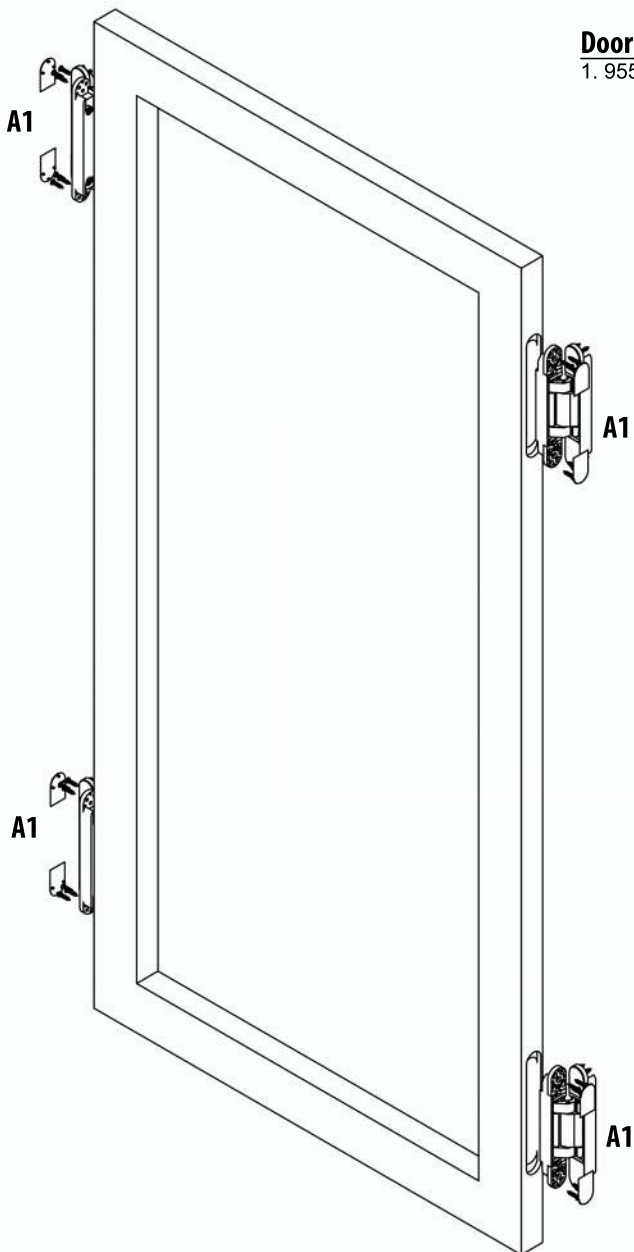

STEP 4

DOOR ASSEMBLY - DOOR 4



Door 4 (D4) - Parts :

1. 95555 Hinge x 2
2. 04851 Wheel Hanger x1
3. 44364 Bottom Guide x 1

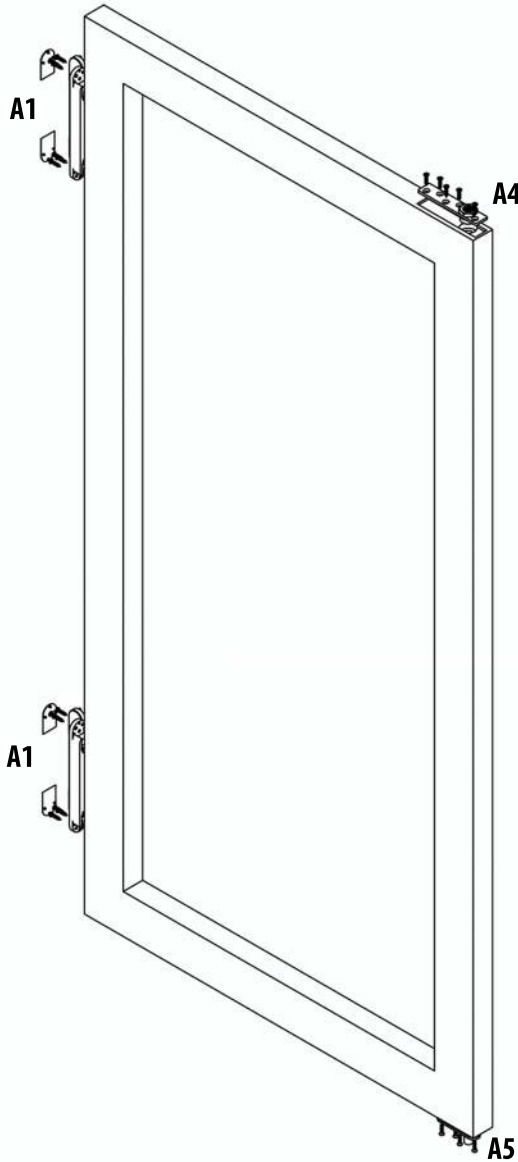

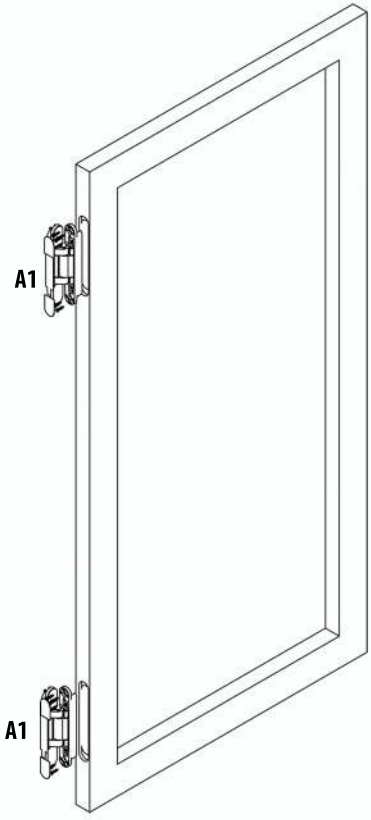

Door 5 (D5) - Parts :

- 1. 95555 Hinges x 2

Door Configuration

Door configuration	No.of doors	Figure to use
	2 Doors	D1+ D4
	3 Doors	D1+ D2 + D5
	4 Doors	D1+ D2 + D3 + D4
	5 Doors	D1+ D2 + D3 + D2 + D5
	6 Doors	D1+ D2 + D3 + D2 + D3 + D4

STEP 5

TOP PIVOT INSTALLATION

5.1

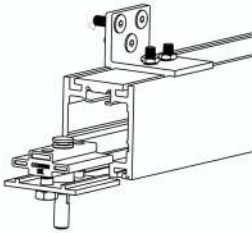

Insert the top pivot assembly into the track

5.2

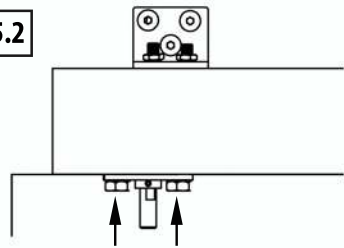

Fix the screws by tightening

5.3

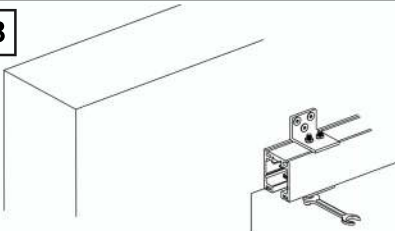

Secure pivot position by tightening the screws with spanner

5.4

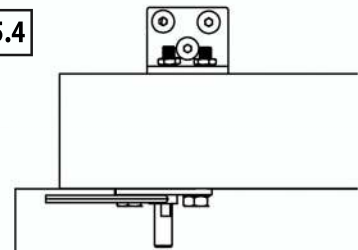

Loosen the grub screw with Allen key

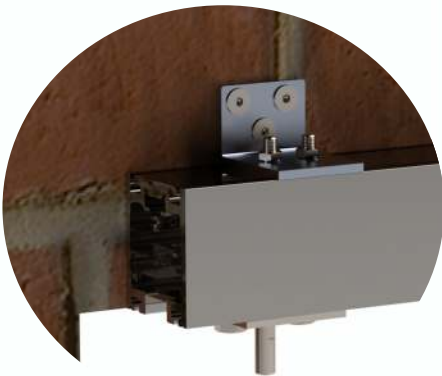

(Pivot inside the track)

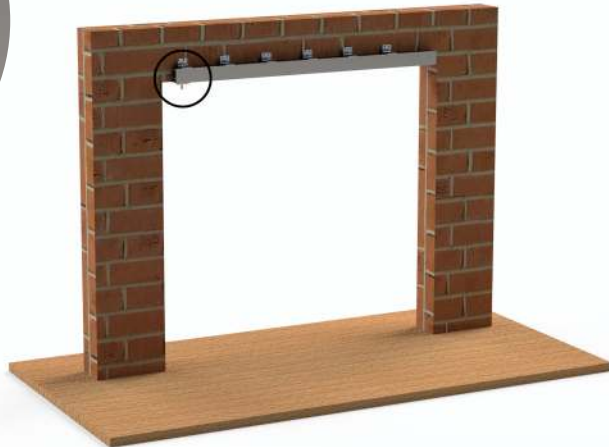

STEP 6

BOTTOM PIVOT & CHANNEL INSTALLATION

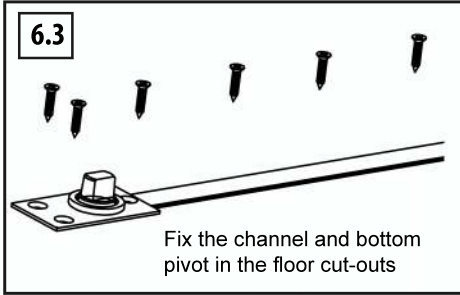
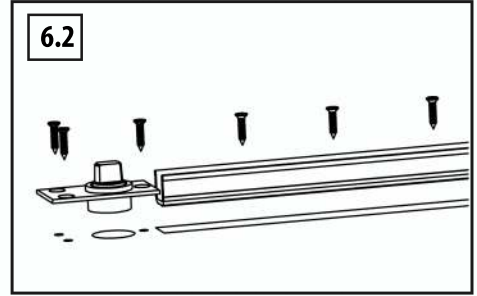
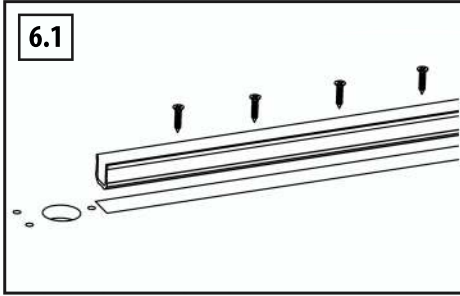

Fix the channel and bottom pivot in the floor cut-outs

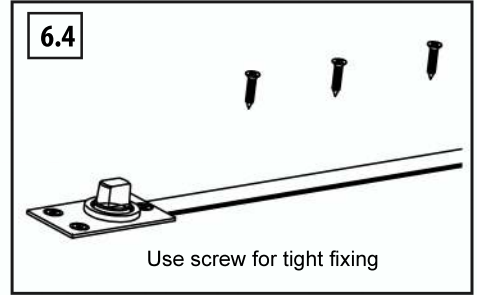

Use screw for tight fixing

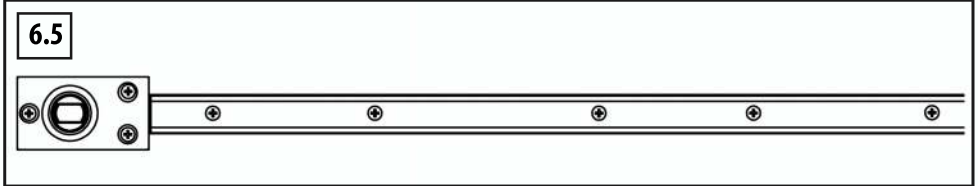

CUT - OUT DETAILS

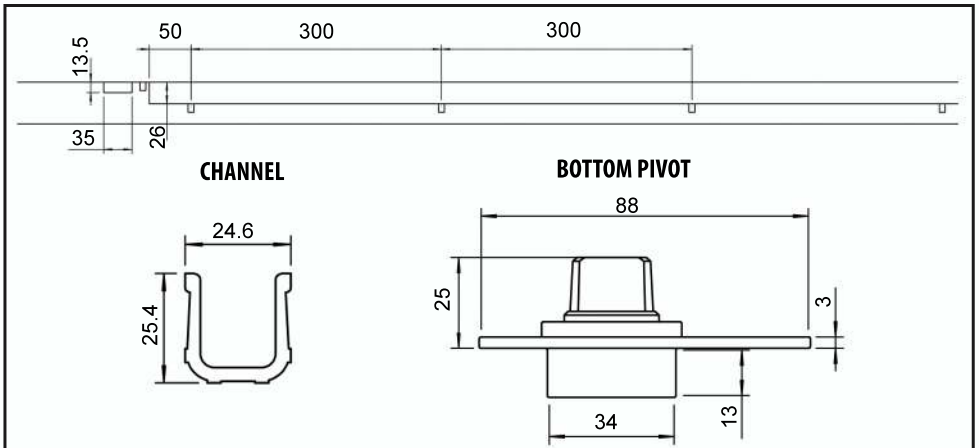

STEP 7

INSTALLING PIVOT DOOR (D1)

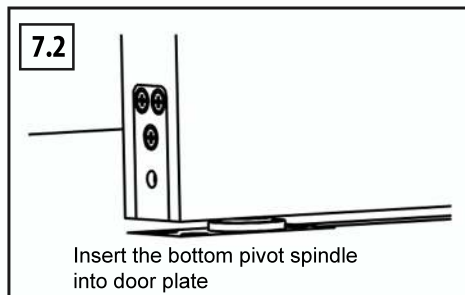
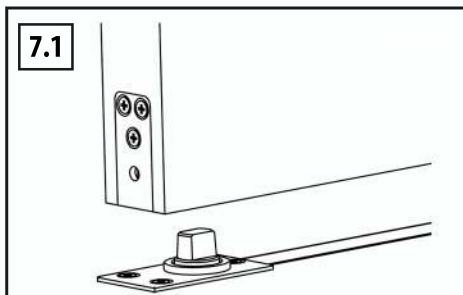

Insert the bottom pivot spindle into door plate

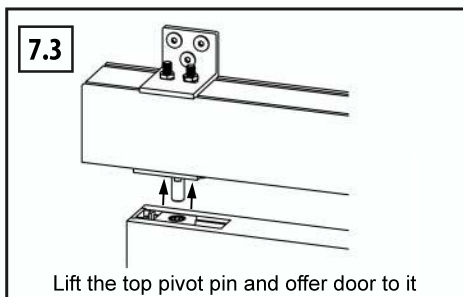

Lift the top pivot pin and offer door to it

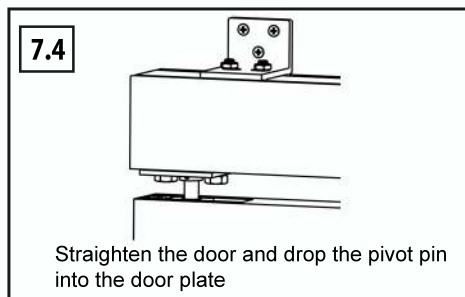

Straighten the door and drop the pivot pin into the door plate

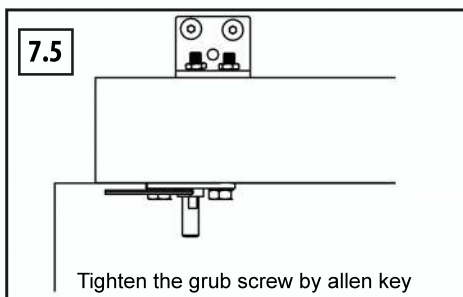

Tighten the grub screw by allen key



1.



2.

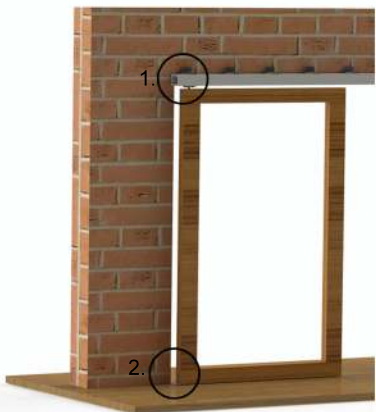

8.1

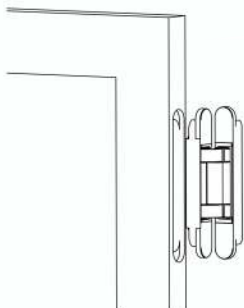

Insert the hinges in to the door's cut outs

8.2

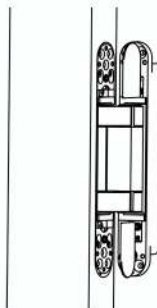

Remove hinge caps

8.3

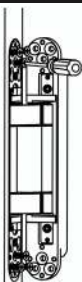

Fix the hinges into the door with screws

8.4

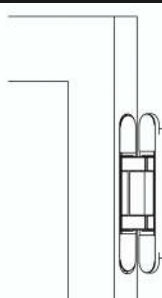

Refit the caps



STEP 9

INSTALLING HANGER DOOR (D2)

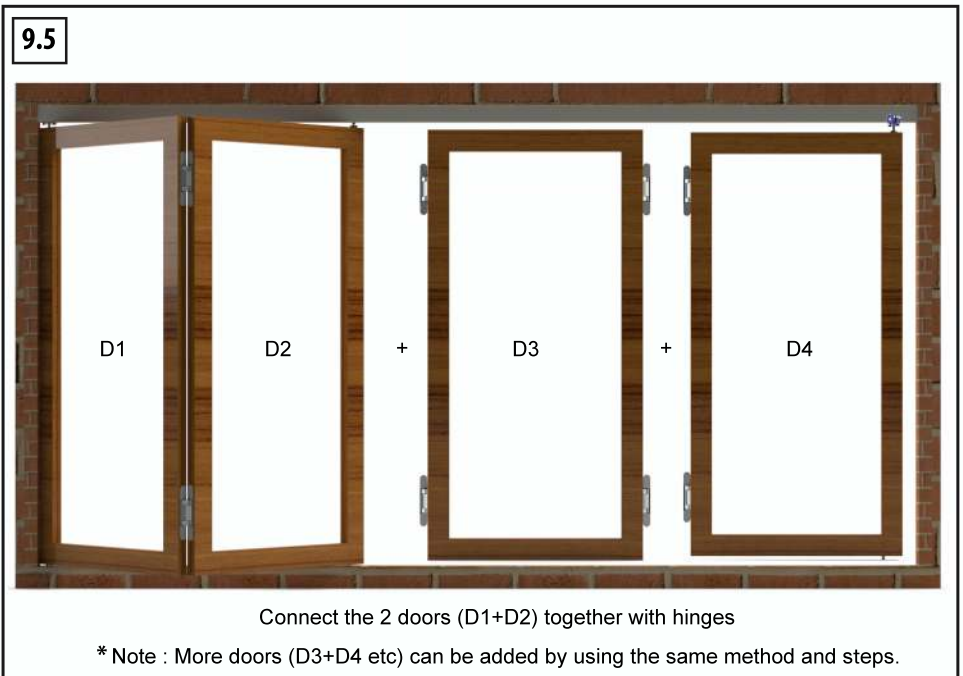
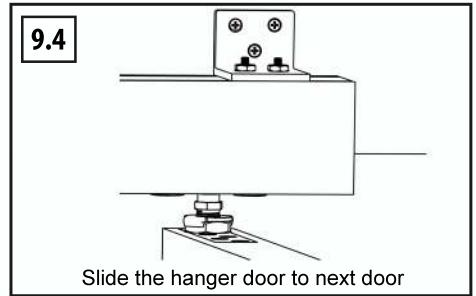
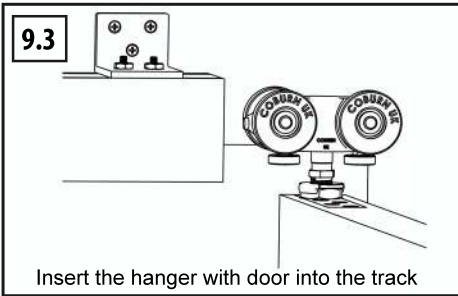
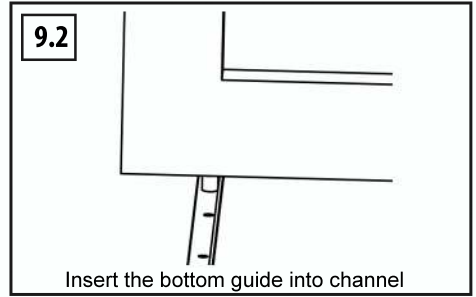
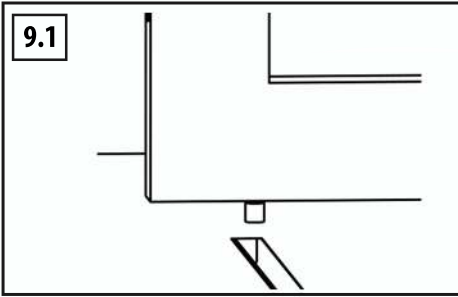

PIVOT DOOR PLATE ADJUSTMENT

Top Pivot Door Plate

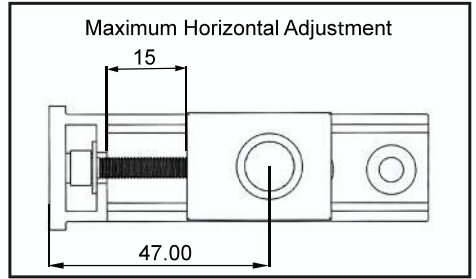
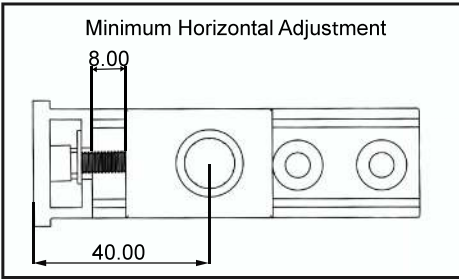
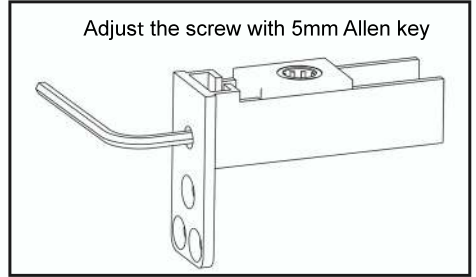
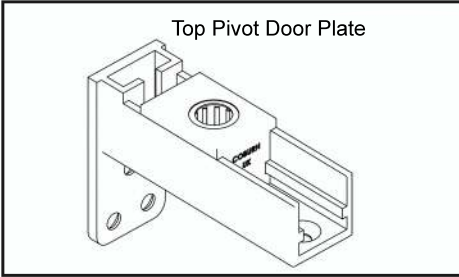

Bottom Pivot Door Plate

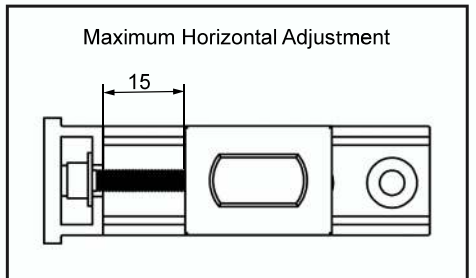
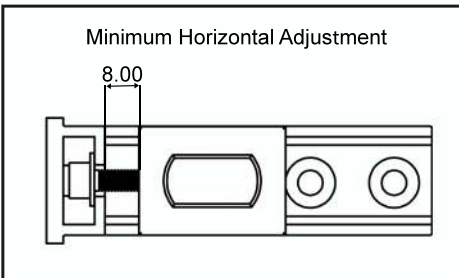
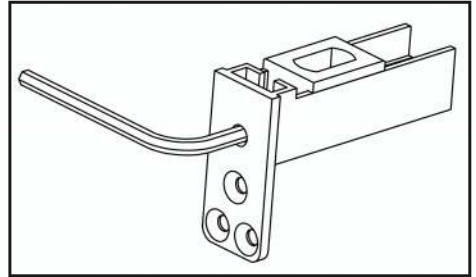
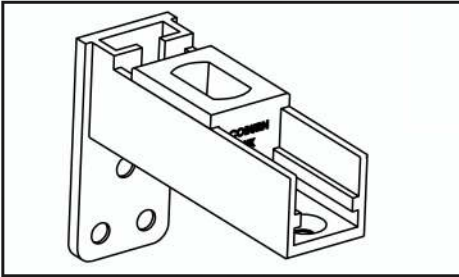

Hinge

3D adjustable hinge with high load bearing capacity. A pair of hinges required for doors up to 2250 mm height. Please follow the table below for number of hinges required between two doors.

Door Height	No.of Hinges
up to 2250 mm	2
2251 - 3000 mm	3
3001 - 4000 mm	4
4001 - 4500 mm	5

Hinge Positions

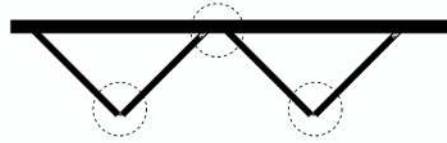

3D Hinge Adjustusment

Horizontal And Vertical Adjustment

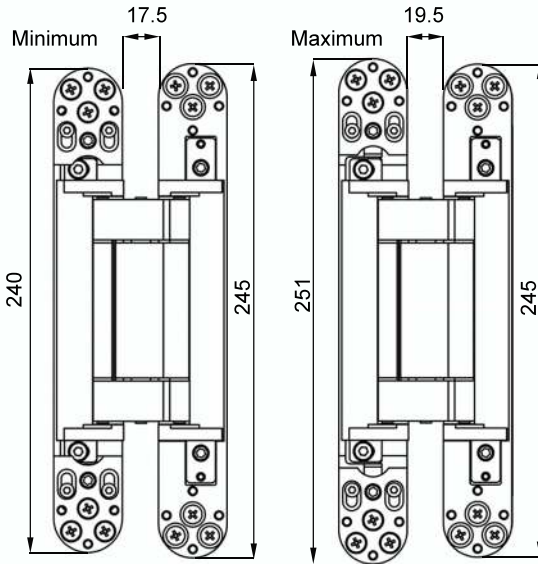

Depth Adjustment

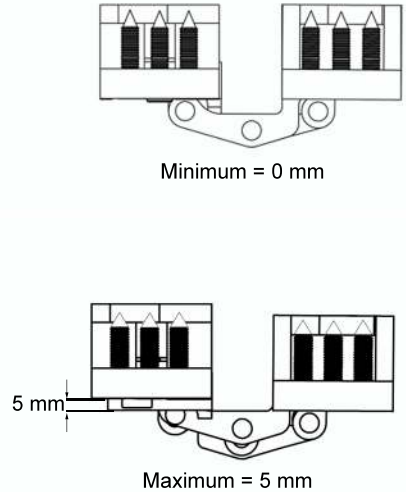

INSTALLING FLUSH HANDLE

Handles

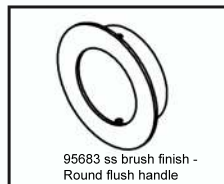
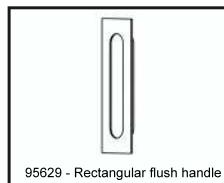
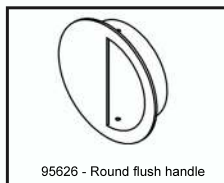
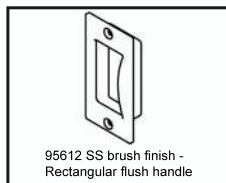

4 Door Assembly

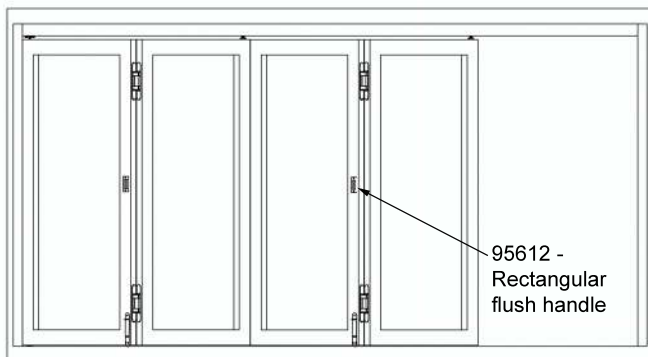

Note : 95612 rectangular flush handle used in the 4 doors assembly

95612 - Flush Handle

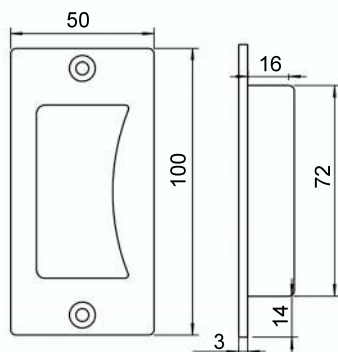

3 Door Assembly

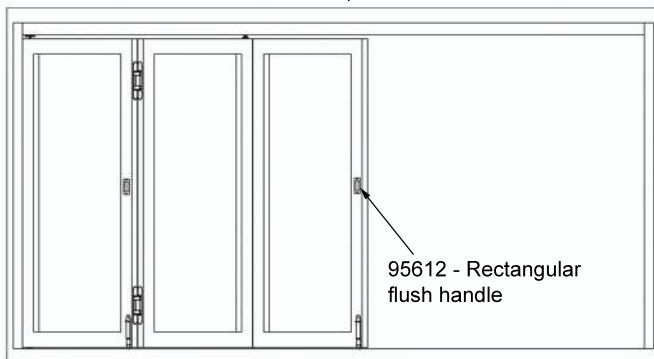

Note : 95612 rectangular flush handle used in the 3 doors assembly

95612 - Cut-out Details

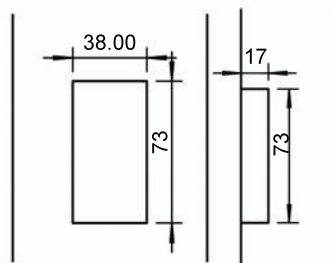

INSTALLING FLUSH BOLT

Bolts

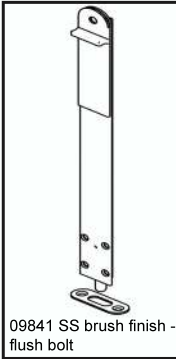

09841 SS brush finish - flush bolt

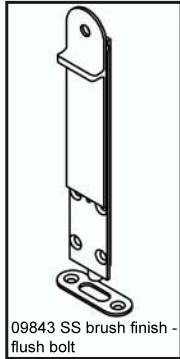

09843 SS brush finish - flush bolt

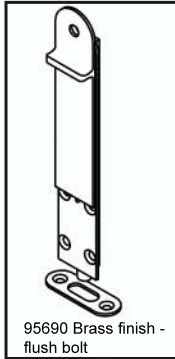

95690 Brass finish - flush bolt

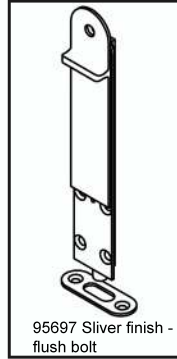

95697 Silver finish - flush bolt

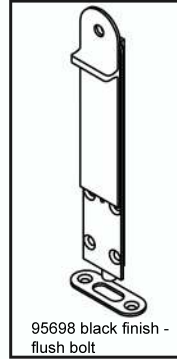

95698 black finish - flush bolt

09841- Flush bolt (400mm)

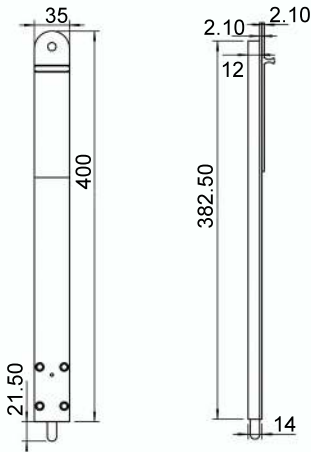

09843- Flush bolt (200mm)

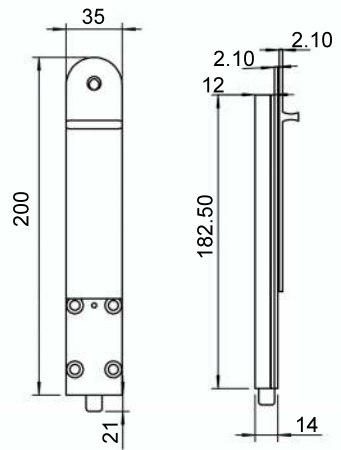

Cut-out Details

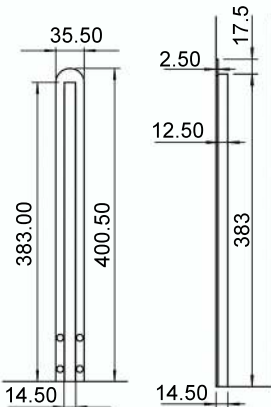

Cut-out Details

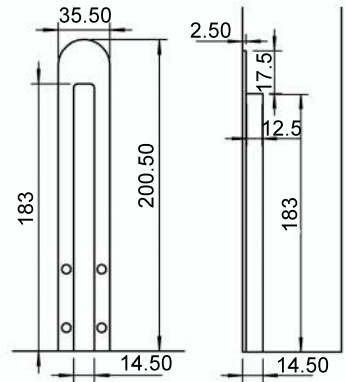

INSTALLING HOLD CATCH

Hold Catch

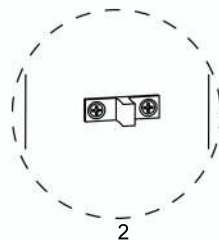
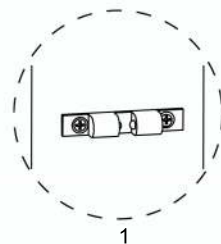
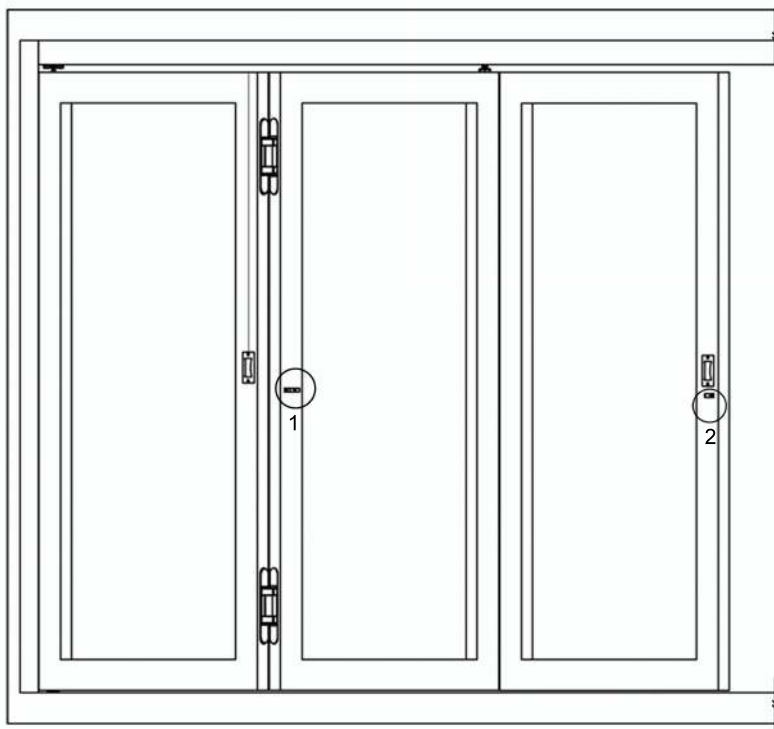
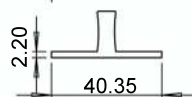
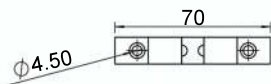
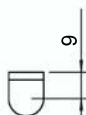
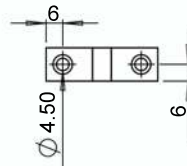
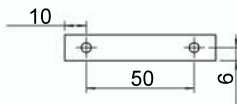
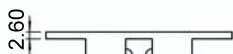
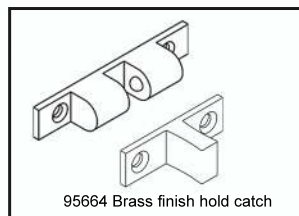
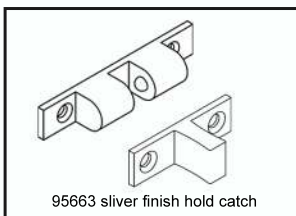
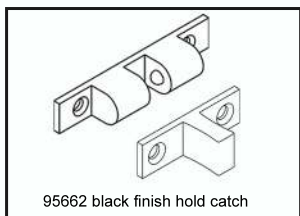

Note : Hold back catch required only on odd door leaf configurations.